



— BUREAU OF —  
RECLAMATION

Final Report No. ST-2023-20048/HL-2023-06

# Utilizing the Winter-Kennedy Method for Hydropower Flow Measurement

Research and Development Office

**Science and Technology**

Research Program



REPORT DOCUMENTATION PAGE				Form Approved OMB No. 0704-0188	
<p>The public reporting burden for this collection of information is estimated to average 1 hour per response, including the time for reviewing instructions, searching existing data sources, gathering and maintaining the data needed, and completing and reviewing the collection of information. Send comments regarding this burden estimate or any other aspect of this collection of information, including suggestions for reducing the burden, to Department of Defense, Washington Headquarters Services, Directorate for Information Operations and Reports (0704-0188), 1215 Jefferson Davis Highway, Suite 1204, Arlington, VA 22202-4302. Respondents should be aware that notwithstanding any other provision of law, no person shall be subject to any penalty for failing to comply with a collection of information if it does not display a currently valid OMB control number.</p> <p>PLEASE DO NOT RETURN YOUR FORM TO THE ABOVE ADDRESS.</p>					
1. REPORT DATE (DD-MM-YYYY) 15-01-2024		2. REPORT TYPE Research		3. DATES COVERED (From - To) October 2020–October 2023	
4. TITLE AND SUBTITLE Utilizing the Winter-Kennedy Method for Hydropower Flow Measurement				5a. CONTRACT NUMBER F220A	
				5b. GRANT NUMBER	
				5c. PROGRAM ELEMENT NUMBER 1541 (S&T)	
6. AUTHOR(S) Josh Mortensen, P.E. Hydraulic Engineer, Hydraulic Investigations and Laboratory Services, 86-68560				5d. PROJECT ID NUMBER Final Report ST-2023-20048 HL-2023-06	
				5e. TASK NUMBER	
				5f. WORK UNIT NUMBER	
7. PERFORMING ORGANIZATION NAME(S) AND ADDRESS(ES) Bureau of Reclamation Technical Service Center Denver Federal Center Denver, CO 80225				8. PERFORMING ORGANIZATION REPORT NUMBER	
9. SPONSORING/MONITORING AGENCY NAME(S) AND ADDRESS(ES) Science and Technology Program Research and Development Office Bureau of Reclamation U.S. Department of the Interior Denver Federal Center PO Box 25007, Denver, CO 80225-0007				10. SPONSOR/MONITOR'S ACRONYM(S) Reclamation	
				11. SPONSOR/MONITOR'S REPORT NUMBER(S) (if applicable) Final Report ST-2023-20048 HL-2023-06	
12. DISTRIBUTION/AVAILABILITY STATEMENT Final Report may be downloaded from <a href="https://www.usbr.gov/research/projects/index.html">https://www.usbr.gov/research/projects/index.html</a>					
13. SUPPLEMENTARY NOTES					
14. ABSTRACT The Winter-Kennedy (WK) method of flow measurement correlates a difference in pressure at a cross-section of the scroll case to the discharge through the hydropower unit. Many of Reclamation's hydropower units include pressure taps configured for WK measurements but few have been used. Utilizing an existing flow measurement system with their original calibration could provide a significant cost savings for flow measurement equipment and provide value for monitoring water quantities or even unit efficiency. Limitations of this method include changes to the condition of the interior pressure taps, penstock surface roughness, coating degradation, and many other factors that influence the calibration. The intent of this study was to determine the value of existing WK systems by comparing flow estimates from original WK calibrations to an absolute flow rate reference. Field tests were done on six different WK pressure tap systems at three Reclamation hydropower plants. Equipment and original calibrations were at least 40 years old for each unit tested. Test results showed that the original calibrations have drifted significantly and that for each case new calibration tests would be required for the flow predictions to be used.					
15. SUBJECT TERMS Flow measurement, hydropower, performance testing, Winter-Kennedy method					
16. SECURITY CLASSIFICATION OF:			17. LIMITATION OF ABSTRACT	18. NUMBER OF PAGES 45	19a. NAME OF RESPONSIBLE PERSON Josh Mortensen
a. REPORT U	b. ABSTRACT U	c. THIS PAGE U			19b. TELEPHONE NUMBER (Include area code) 303-445-2156

## **Mission Statements**

The U.S. Department of the Interior protects and manages the Nation's natural resources and cultural heritage; provides scientific and other information about those resources; honors its trust responsibilities or special commitments to American Indians, Alaska Natives, Native Hawaiians, and affiliated Island Communities.

The mission of the Bureau of Reclamation is to manage, develop, and protect water and related resources in an environmentally and economically sound manner in the interest of the American public.

## **Disclaimer**

Information in this report may not be used for advertising or promotional purchases. The data and findings should not be construed as an endorsement of any product or firm by the Bureau of Reclamation, Department of Interior, or Federal Government. The products evaluated in the report were evaluated for purposes specific to the Bureau of Reclamation mission. Reclamation gives no warranties or guarantees, expressed or implied, for the products evaluated in this report, including merchantability or fitness for a particular purpose.

Information in this report may not be used for advertising or promotional purposes. The data and findings should not be construed as an endorsement of any product or firm by the Bureau of Reclamation, Department of Interior, or Federal Government. The products evaluated in the report were evaluated for purposes specific to the Bureau of Reclamation mission. Reclamation gives no warranties or guarantees, expressed or implied, for the products evaluated in this report, including merchantability or fitness for a particular purpose.

## **Acknowledgements**

The Bureau of Reclamation's Science and Technology Program sponsored this research. Field testing was supported by Grand Coulee, Yellowtail, and Blue Mesa Powerplants. Technical support and review were provided by John Germann and Shanna Durham, senior mechanical engineers at the Technical Service Center.

**Cover Image** – Instrumentation connected to Winter-Kennedy piezometer taps at Grand Coulee Powerplant (Bureau of Reclamation).



# **Utilizing the Winter-Kennedy Method for Hydropower Flow Measurement**

**Final Report No. ST-2023-20048  
HL-2023-06**

Prepared by:

**Josh Mortensen, Hydraulic Engineer  
Bureau of Reclamation  
Technical Service Center  
Denver, Colorado**



# Peer Review

## Bureau of Reclamation Research and Development Office Science and Technology Research Program

**Final Report No. ST-2023-20048/HL-2023-06**

**Utilizing the Winter-Kennedy Method for Hydropower Flow Measurement**

---

Prepared by: Josh Mortensen, P.E.  
Hydraulic Engineer, Hydraulic Investigations and Laboratory Services, 86-68560

---

Peer Review by: Shanna Durham, P.E.  
Mechanical Engineer, Turbines and Pumps Group, 86-68470

This document has been reviewed under the Research and Development Office Discretionary peer review process, consistent with Reclamation Policy CMP P14. It does not represent and should not be construed to represent the Bureau of Reclamation's determination, concurrence, or policy.



# Acronyms and Abbreviations

ASME	American Society of Mechanical Engineers
ft <sup>3</sup> /s	cubic feet per second
psi	pounds per square inch
Reclamation	Bureau of Reclamation
WK	Winter-Kennedy Method

## Symbols

Q	discharge
%	percent
$\Delta P$	the pressure difference



# Contents

	Page
1.0	Introduction.....1
1.1.	Background.....1
1.1.1.	Winter-Kennedy Flow Measurement Method .....1
1.1.2.	Benefits and Limitations .....2
2.0	Experimental Method.....4
2.1.	Original Winter-Kennedy Field Tests.....4
2.2.	Comparison Field Tests .....5
3.0	Field Test Results.....6
3.1.	Grand Coulee Powerplant .....6
3.2.	Blue Mesa Powerplant .....10
3.3.	Yellowtail Powerplant .....11
4.0	Discussion and Application .....13
5.0	Conclusions.....14
6.0	References.....15

## Tables

1.—	Hydropower facilities and units used for comparison testing.....	5
2.—	Equation coefficients and exponents derived from original Winter-Kennedy testing.....	5
3.—	Information of testing equipment used in recent comparison field tests .....	5
4.—	Test data compared to discharges predicted by the original Winter-Kennedy equation for Grand Coulee Powerplant G24, pressure taps A–D .....	6
5.—	Test data compared to discharges predicted by the original Winter-Kennedy equation for Grand Coulee Powerplant G24, pressure taps B–D .....	7
6.—	Test data compared to discharges predicted by the original Winter-Kennedy equation for Grand Coulee Powerplant G24, pressure taps C–D .....	9
7.—	Test data compared to discharges predicted by the original Winter-Kennedy equation for Blue Mesa Powerplant Unit 1, pressure taps R <sub>2</sub> –R <sub>4</sub> .....	10
8.—	Test data compared to discharges predicted by the original Winter-Kennedy equation for Yellowtail Powerplant, Unit 2, pressure taps P <sub>1</sub> –P <sub>3</sub> .....	11
9.—	Test data compared to discharges predicted by the original Winter-Kennedy equation for Yellowtail Powerplant, Unit 2, pressure taps P <sub>1</sub> –P <sub>4</sub> .....	12

## Figures

1.—	Schematic of typical Winter-Kennedy pressure taps for a spiral type scroll case, common for Reclamation Francis type turbine runners (ASME 2018). .....	2
2.—	Example of a pressure tap insert that protrudes inside the pipe wall causing an offset.....	3

3.—Example of a pressure tap with corrosion and coating loss causing surface irregularities near the tap. ....	3
4.—Example of a pressure tap that has been covered by a repair coating.....	4
5.—Comparison of test data from 2023 to the original 1983 test for Grand Coulee Powerplant taps A–D.....	7
6.—Comparison of test data from 2023 to the original 1983 test for Grand Coulee Powerplant taps B–D.....	8
7.—Comparison of test data from 2023 to the original 1983 test for Grand Coulee Powerplant taps C–D.....	9
8.—Comparison of test data from 2021 to the original 1968 test for Blue Mesa Powerplant taps R <sub>2</sub> –R <sub>4</sub> .....	10
9.—Comparison of test data from 2021 to the original 1967 test for Yellowtail Powerplant Powerplant taps P <sub>1</sub> –P <sub>3</sub> . ....	12
10.—Comparison of test data from 2021 to the original 1967 test for Yellowtail Powerplant taps P <sub>1</sub> –P <sub>4</sub> . ....	13

## Appendices

- A Literature Review Summary
- B Grand Coulee Dam Winter-Kennedy Test Report 2023
- C Original Winter-Kennedy Test Data

# 1.0 Introduction

Reliable discharge measurements (i.e., volumetric flowrate of water, or flow) in hydropower penstocks are important to measure unit efficiency and quantify the amount of water passed through the powerplant. There are two general methods of discharge measurement: absolute and relative. Absolute methods are very accurate and are accepted by industry standards to determine unit efficiency (American Society of Mechanical Engineers [ASME] 2018), however, installation and maintenance costs can be quite high. Relative methods, such as Winter-Kennedy, rely upon differential pressure measurements indexed to a discharge. This method is less accurate and not accepted by industry standards for performance testing but is significantly less expensive. Most Bureau of Reclamation (Reclamation) hydropower units already have Winter-Kennedy pressure taps for discharge measurement, but often go unused. Many facilities have lost institutional knowledge and don't understand how these taps should be utilized, what they are for, and in some cases don't even know they exist at their facility.

The main objective of this research is to compare the accuracy of Winter-Kennedy taps and their original calibrations to absolute discharge measurements to help determine the value they could add to Reclamation hydropower facilities. While Winter-Kennedy measurements cannot be used to officially determine unit efficiency, they could be more widely applied to monitor unit efficiency, identify potential operational issues or maintenance needs, and provide a redundant flow measurement method at a minimal cost.

## 1.1. Background

### 1.1.1. Winter-Kennedy Flow Measurement Method

The Winter-Kennedy (WK) flow measurement method was developed by I.A. Winter and A.M. Kennedy in 1933 (Winter and Kennedy 1933). It correlates a difference in pressure at a cross section of the scroll case to the discharge through the penstock. The pressure difference is measured from taps located at different sides of the conduit, typically one or more at the top and a reference tap at the side (see figure 1 as an example). Discharge ( $Q$ ) is correlated to the pressure difference ( $\Delta P$ ) through the relationship shown in equation 1 where the coefficient  $K$  and exponent  $n$  are determined through experimental testing where both  $Q$  and  $\Delta P$  are measured over a range of operating conditions. Both  $K$  and  $n$  are dependent on the geometry of the conduit and  $n$  is typically close to 0.5 (ASME 2018) but both calibration factors are unique to the unit for which they are tested.

$$Q = K (\Delta P)^n \quad \text{Equation (1)}$$

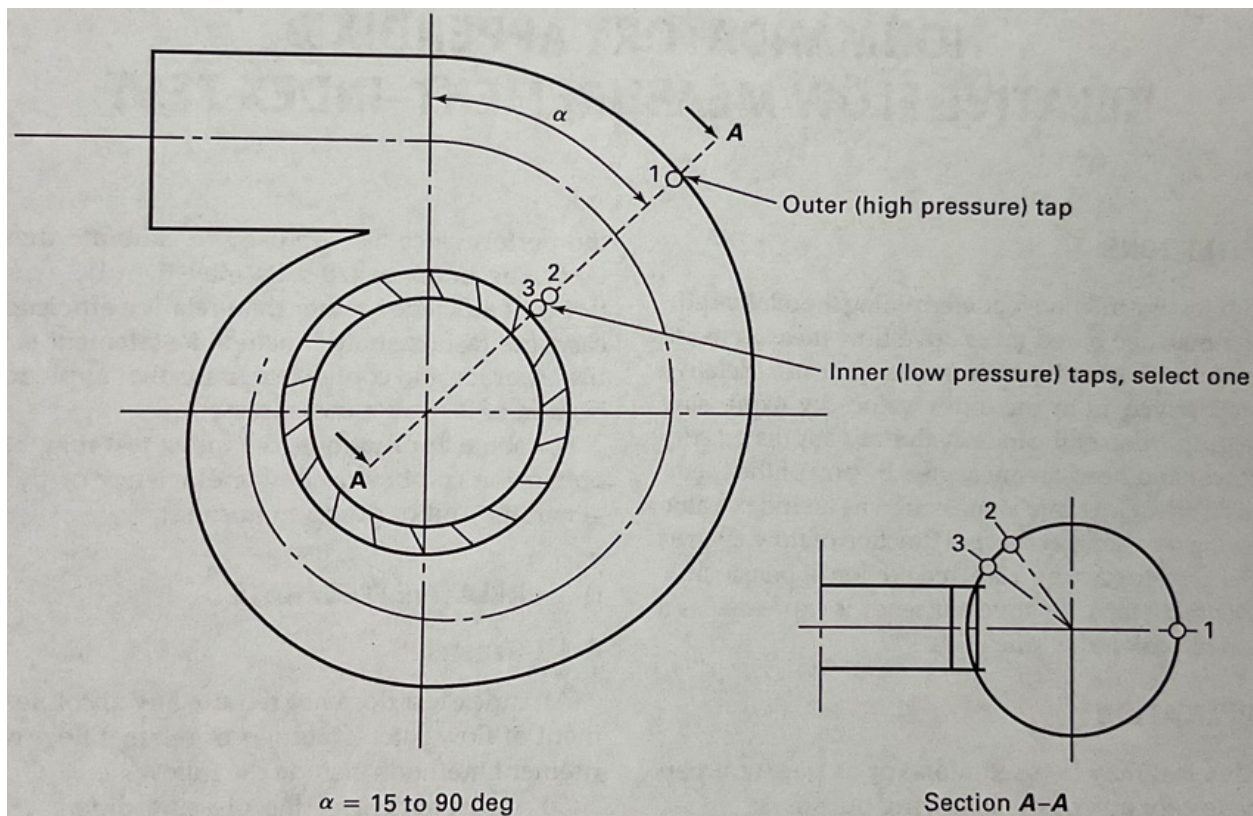

Figure 1.—Schematic of typical Winter-Kennedy pressure taps for a spiral type scroll case, common for Reclamation Francis type turbine runners (ASME 2018).

### 1.1.2. Benefits and Limitations

As with any flow measurement method, the WK method has both benefits and limitations. Benefits include its simplicity and relative low cost. The pressure taps and piping are already in place for many Reclamation hydropower units and only require a device for measuring differential pressure. A method to measure discharge through a unit without having to install an expensive measurement system such as ultrasonic transducers may save time and costs. Also, a redundant flow measurement system that can be used reliably when the primary system (ultrasonic flow meter in most cases) is out of service may be very valuable and relatively inexpensive to setup and maintain (see appendix B as an example).

Limitations of this method include inaccurate flow estimates at low discharges when the pressure differential reading is small, and variation of pressure readings due to changes to the scroll case, penstock, or pressure taps. Examples of this include modifications to the intake, penstock or scroll case geometry, wear or changes near the pressure taps (e.g., coating failure/repair, welds, grinding, etc.), or any other changes that influence the flow patterns in the conduit that affect pressure readings at the taps (Rau and Eissner 2014). Examples of adverse pressure tap conditions are shown in figures 2–4. Also, a literature review including experiences with Winter-Kennedy flow measurement is summarized in appendix A.



Figure 2.—Example of a pressure tap insert that protrudes inside the pipe wall causing an offset.



Figure 3.—Example of a pressure tap with corrosion and coating loss causing surface irregularities near the tap.



Figure 4.—Example of a pressure tap that has been covered by a repair coating.

## 2.0 Experimental Method

### 2.1. Original Winter-Kennedy Field Tests

Field test measurements were used to compare Winter-Kennedy discharge estimates from original calibration data to a reference flow reading from an absolute flow measurement (ultrasonic flow meter in this case). Facilities that have Winter-Kennedy taps, with a known calibration from original testing (typically by the Pressure-Time Method, also known as the Gibson Method), and an absolute flow measurement system were identified for field testing. Table 1 and table 2 show facilities and hydropower units that meet these criteria and were used for field testing. Original WK test data for each facility are provided in appendix C.

Table 1.—Hydropower facilities and units used for comparison testing

Unit	Flow Range (ft <sup>3</sup> /s)	Rated Power (MW)
Grand Coulee Powerplant G24	< 15,000–36,000	805
Blue Mesa Powerplant Unit 1	< 400–2,000	43.2
Yellowtail Powerplant Unit 2	< 800–2,500	62.5

Table 2.—Equation coefficients and exponents derived from original Winter-Kennedy testing

Facility	Unit	Taps	K	<i>n</i>	R <sup>2</sup> Correlation	Test Date
Grand Coulee Powerplant	G24	A–D	7726.3588	0.5063	0.9747	June 1983
	G24	B–D	8337.8116	0.5043	0.9737	June 1983
	G24	C–D	9204.0686	0.5012	0.9776	June 1983
Blue Mesa Powerplant	2	R <sub>2</sub> –R <sub>4</sub>	681.332	0.51538	0.9757	August 1968
Yellowtail Powerplant	2	P <sub>1</sub> –P <sub>3</sub>	695.526	0.52738	0.9788	October 1967
	2	P <sub>1</sub> –P <sub>4</sub>	609.650	0.52531	0.9815	October 1967

Grand Coulee Powerplant G20 and Palisades Powerplant Units 1–4 were also tested but there were no original WK calibration data to compare to, so they are omitted from this research report.

## 2.2. Comparison Field Tests

Field testing took place in 2021 and 2023 which coincided with other performance or commissioning testing concurrently at each facility. Information about the data acquisition and test equipment are provided in table 3. At Yellowtail Powerplant, results from one of the pressure tap configurations (P<sub>2</sub>–P<sub>4</sub>) was not used in this comparison due to a bad differential pressure sensor.

A thorough discussion of test measurement uncertainties is not provided here but included in the Grand Coulee Powerplant report in appendix B.

Table 3.—Information of testing equipment used in recent comparison field tests

Facility	Test Date	Discharge		Differential Pressure		Averaging Time
		Flow Meter	Accuracy	Sensor	Accuracy	Minutes
Grand Coulee Powerplant	January 2023	8-Path Accusonic	1.00%	Rosemount 3051	0.10%	7
Blue Mesa Powerplant	April 2021	8-Path Accusonic	0.50%	Rosemount 3051	0.10%	3
Yellowtail Powerplant	June 2021	8-Path Accusonic	0.50%	Rosemount 3051	0.10%	5

## 3.0 Field Test Results

### 3.1. Grand Coulee Powerplant

Test data comparing WK flow estimates to absolute measurements at Grand Coulee Powerplant are shown in tables 4–6 and figures 5–7 for all three pressure tap configurations. Differences were quite large (near 10 percent [%]) for the lowest discharges but then improved as the flow rate increased in all three cases. A similar trend was found in the study performed by Almquist et al. (2011), although differences were greater for cases in the current study.

Table 4.—Test data compared to discharges predicted by the original Winter-Kennedy equation for Grand Coulee Powerplant G24, pressure taps A–D

2023 Test Data – Grand Coulee Powerplant G24 (A–D)			
Discharge (ft <sup>3</sup> /s)	Differential Pressure (inch Hg)	WK Discharge (ft <sup>3</sup> /s)	Difference (%)
10,818	1.527	9,573	11.5%
12,906	2.327	11,850	8.2%
14,807	3.119	13,744	7.2%
18,938	5.255	17,898	5.5%
22,859	7.757	21,799	4.6%
24,728	9.136	23,681	4.2%
25,655	9.805	24,545	4.3%
26,729	10.663	25,608	4.2%
30,495	13.827	29,209	4.2%
31,872	15.262	30,707	3.7%
33,204	16.555	31,998	3.6%
34,639	18.064	33,442	3.5%
35,018	18.355	33,714	3.7%

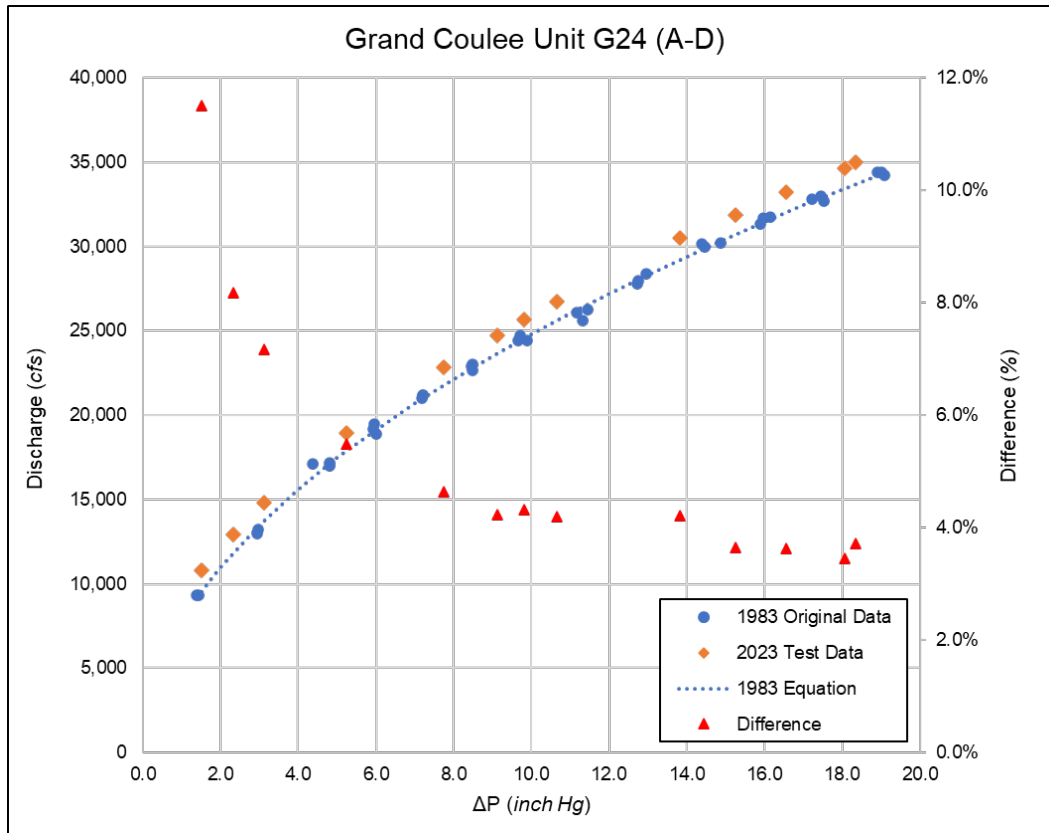

Figure 5.—Comparison of test data from 2023 to the original 1983 test for Grand Coulee Powerplant taps A–D.

Table 5.—Test data compared to discharges predicted by the original Winter-Kennedy equation for Grand Coulee Powerplant G24, pressure taps B–D

2023 Test Data – Grand Coulee Powerplant G24 (B–D)			
Discharge (ft <sup>3</sup> /s)	Differential Pressure (inch Hg)	WK Discharge (ft <sup>3</sup> /s)	Difference (%)
10,818	1.317	9,581	11.4%
12,906	2.050	11,976	7.2%
14,807	2.757	13,904	6.1%
18,938	4.504	17,809	6.0%
22,859	6.699	21,757	4.8%
24,728	7.898	23,641	4.4%
25,655	8.484	24,510	4.5%
26,729	9.248	25,599	4.2%
30,495	12.074	29,283	4.0%
31,872	13.224	30,659	3.8%
33,204	14.511	32,129	3.2%
34,639	15.783	33,520	3.2%
35,018	15.985	33,735	3.7%

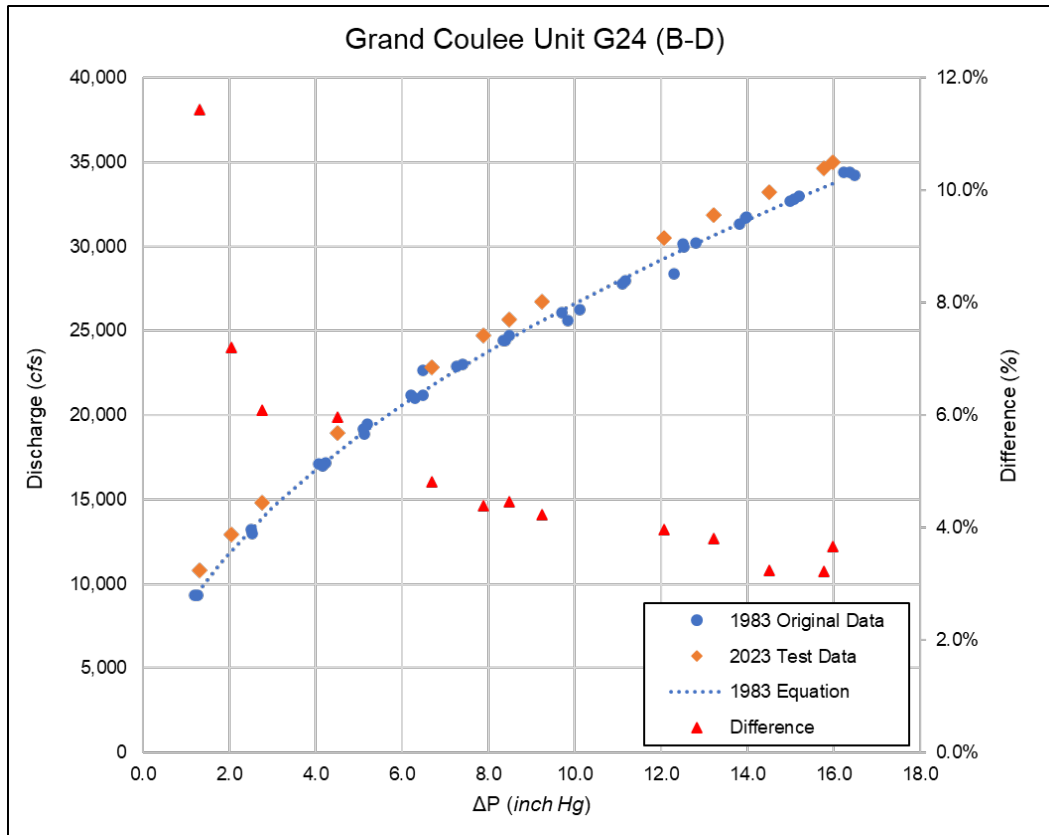

Figure 6.—Comparison of test data from 2023 to the original 1983 test for Grand Coulee Powerplant taps B–D.

Table 6.—Test data compared to discharges predicted by the original Winter-Kennedy equation for Grand Coulee Powerplant G24, pressure taps C–D

2023 Test Data – Grand Coulee Powerplant G24 (C–D)			
Discharge (ft <sup>3</sup> /s)	Differential Pressure (inch Hg)	WK Discharge (ft <sup>3</sup> /s)	Difference (%)
10,818	0.987	9,146	15.5%
12,906	1.594	11,628	9.9%
14,807	2.181	13,604	8.1%
18,938	3.551	17,370	8.3%
22,859	5.357	21,345	6.6%
24,728	6.340	23,227	6.1%
25,655	6.792	24,043	6.3%
26,729	7.417	25,127	6.0%
30,495	9.775	28,855	5.4%
31,872	10.679	30,163	5.4%
33,204	11.764	31,662	4.6%
34,639	12.794	33,023	4.7%
35,018	12.951	33,225	5.1%

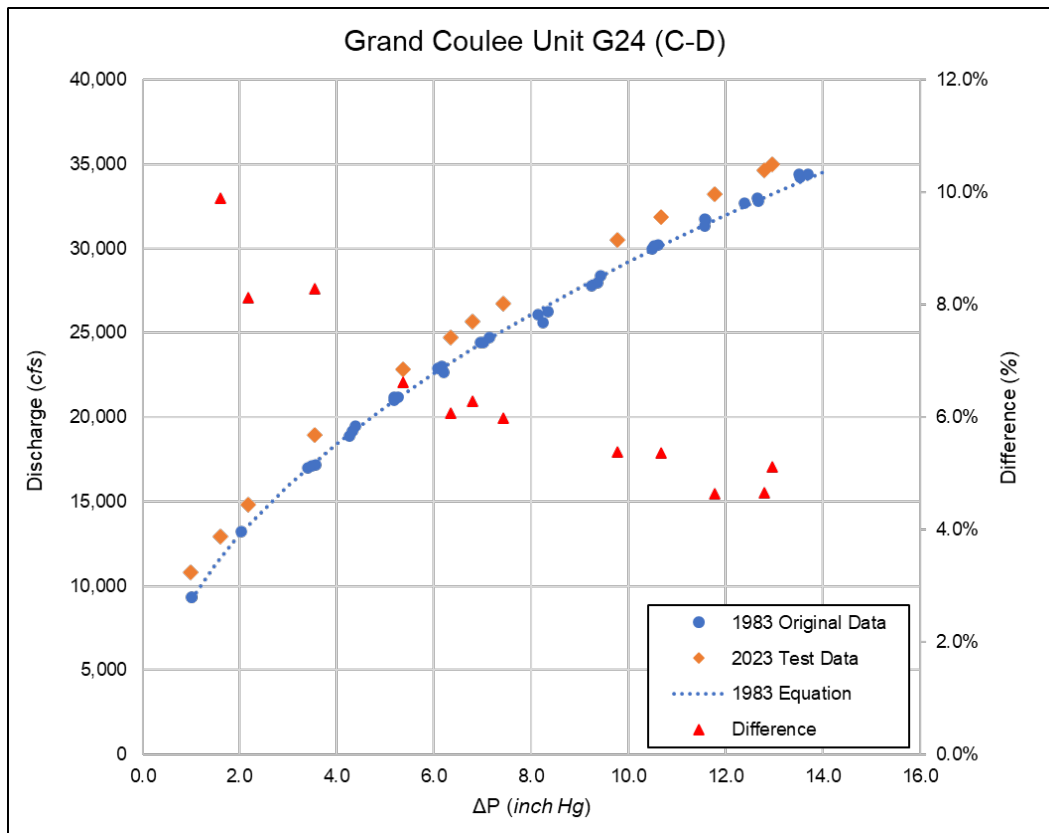

Figure 7.—Comparison of test data from 2023 to the original 1983 test for Grand Coulee Powerplant taps C–D.

### 3.2. Blue Mesa Powerplant

Test data comparing WK flow estimates to absolute measurements at Blue Mesa Powerplant are shown in table 7 and figure 8 for the single pressure tap configuration. A different trend was seen in these data where the estimated WK flow was lower than the reference measurement. Differences were quite large (near -10%) for the lowest discharges but then improved as the flow rate increased.

Table 7.—Test data compared to discharges predicted by the original Winter-Kennedy equation for Blue Mesa Powerplant Unit 1, pressure taps R<sub>2</sub>–R<sub>4</sub>.

2021 Test Data - Blue Mesa Powerplant Unit 1 (R <sub>2</sub> –R <sub>4</sub> )			
Discharge (ft <sup>3</sup> /s)	Differential Pressure (inch Hg)	WK Discharge (ft <sup>3</sup> /s)	Difference (%)
342.1	0.280	354	-3.4%
556.2	0.740	584	-4.9%
760.3	1.408	813	-6.9%
943.9	2.174	1,017	-7.7%
1,159.8	3.238	1,248	-7.6%
1,344.9	4.410	1,464	-8.8%
1,666.1	6.662	1,811	-8.7%

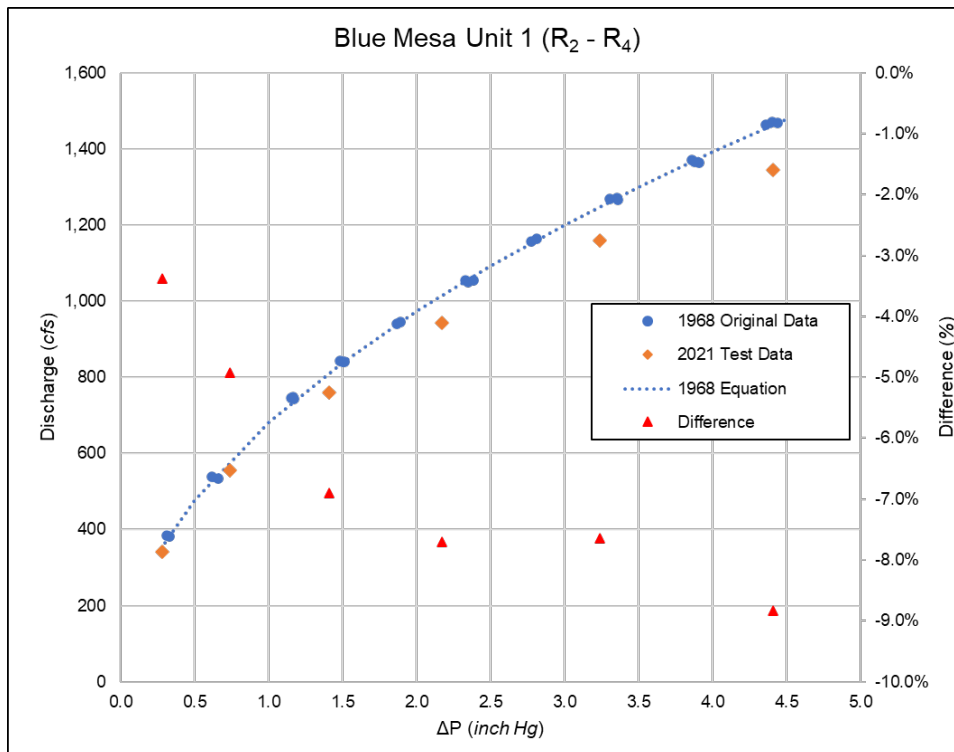

Figure 8.—Comparison of test data from 2021 to the original 1968 test for Blue Mesa Powerplant taps R<sub>2</sub>–R<sub>4</sub>.

### 3.3. Yellowtail Powerplant

Test data comparing WK flow estimates to absolute measurements at Yellowtail Powerplant are shown in tables 8 and 9 and figures 9 and 10 for both pressure tap configuration. The estimated WK flow was greater than the reference measurement similar to results from Grand Coulee. Again, differences were quite large (near 10%) for the lowest discharges but then improved slightly as the flow rate increased. At the highest flow the difference was still quite large, 7.5% and 8.7%.

Results from a third pressure tap configuration (P<sub>2</sub>-P<sub>4</sub>) were not provided due to issues with the differential pressure sensor for that configuration.

Table 8.—Test data compared to discharges predicted by the original Winter-Kennedy equation for Yellowtail Powerplant, Unit 2, pressure taps P<sub>1</sub>-P<sub>3</sub>

2021 Test Data Yellowtail Powerplant Unit 2 (P <sub>1</sub> -P <sub>3</sub> )			
Discharge (ft <sup>3</sup> /s)	Differential Pressure (inch Hg)	WK Discharge (ft <sup>3</sup> /s)	Difference (%)
1,955.2	6.128	1,809	7.5%
1,857.5	5.515	1,712	7.9%
1,740.9	4.844	1,598	8.2%
1,617.5	4.204	1,483	8.3%
1,617.5	4.204	1,483	8.3%
1,383.4	3.001	1,242	10.2%
1,242.9	2.445	1,115	10.3%
1,111.0	1.969	994	10.5%
982.3	1.528	870	11.5%

## Utilizing the Winter-Kennedy Method for Hydropower Flow Measurement

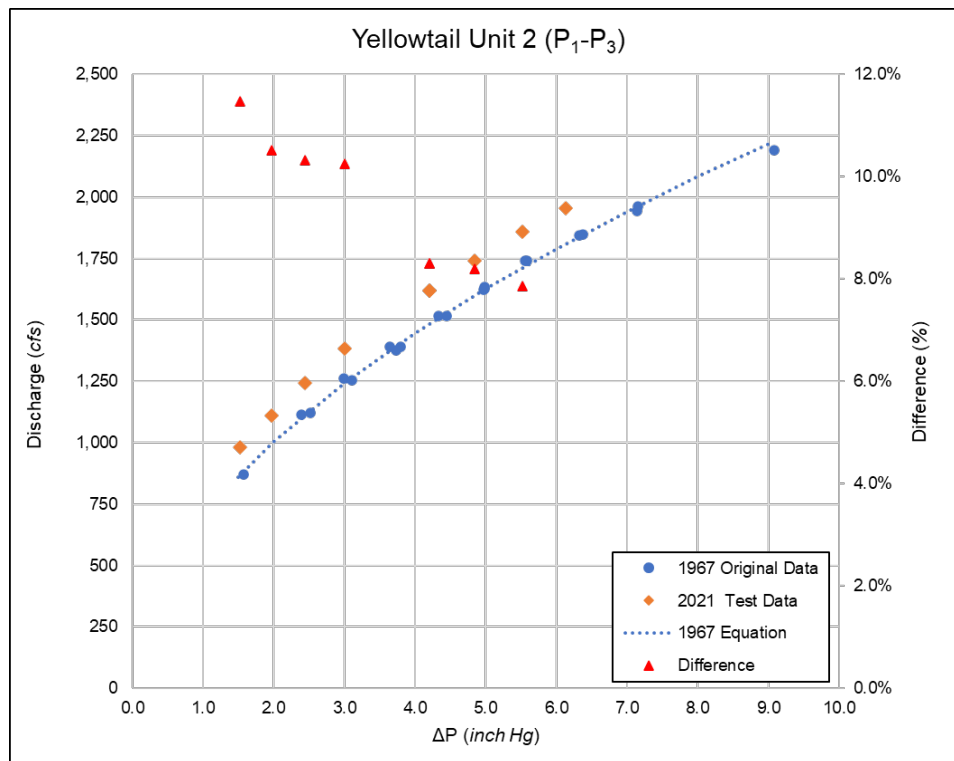

Figure 9.—Comparison of test data from 2021 to the original 1967 test for Yellowtail Powerplant taps P<sub>1</sub>-P<sub>3</sub>.

Table 9.—Test data compared to discharges predicted by the original Winter-Kennedy equation for Yellowtail Powerplant, Unit 2, pressure taps P<sub>1</sub>-P<sub>4</sub>

2021 Test Data Yellowtail Powerplant Unit 2 (P <sub>1</sub> -P <sub>4</sub> )			
Discharge (ft <sup>3</sup> /s)	Differential Pressure (inch Hg)	WK Discharge (ft <sup>3</sup> /s)	Difference (%)
1,955.2	7.731	1,785	8.7%
1,857.5	6.934	1,686	9.2%
1,740.9	6.094	1,575	9.5%
1,617.5	5.298	1,464	9.5%
1,617.5	5.298	1,464	9.5%
1,383.4	3.857	1,239	10.4%
1,242.9	3.142	1,113	10.5%
1,111.0	2.537	994	10.5%
982.3	1.992	876	10.9%

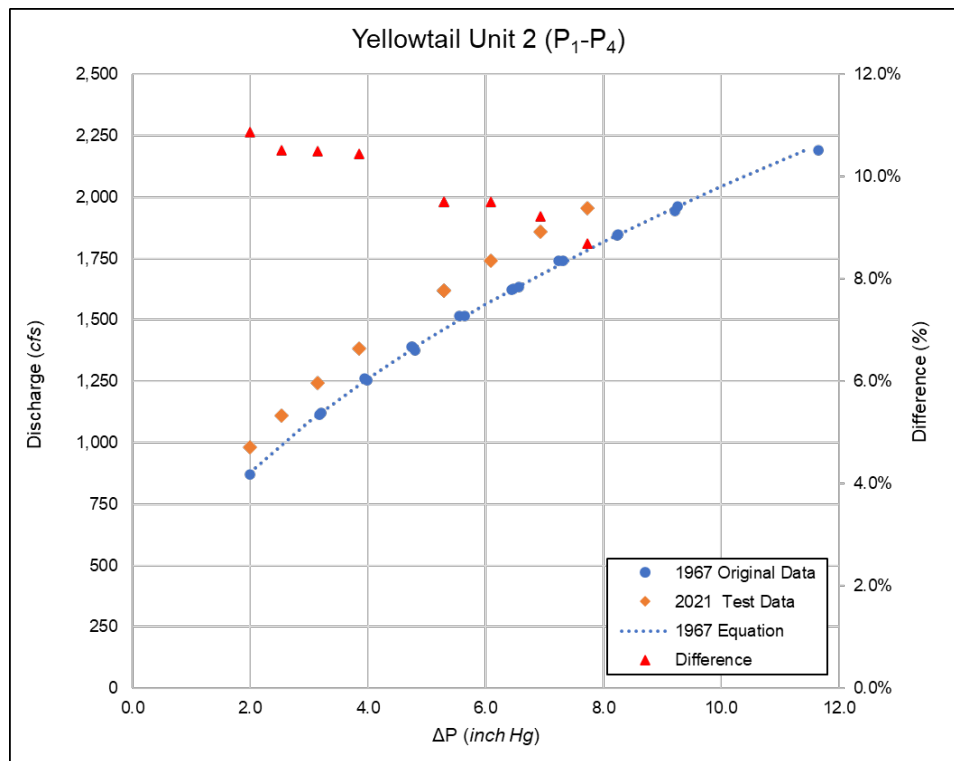

Figure 10.—Comparison of test data from 2021 to the original 1967 test for Yellowtail Powerplant taps P<sub>1</sub>–P<sub>4</sub>.

## 4.0 Discussion and Application

For all six configurations tested, the WK flow estimates from the original calibration data would provide little value if used today independently without a recalibration due to the large differences from the reference flows. This is certainly true if using this flow estimate for monitoring unit performance where the flow measurement usually has the greatest contribution to the overall uncertainty of the efficiency measurement. While generally considered a reliable flow measurement method (see good correlations in table 2 for original calibration data, and low uncertainties in appendix B for recent calibration data), results from this study suggest WK taps require recalibration and maintenance.

The cause for large differences in the WK flow estimates from the reference flow measurements could not be determined. Unfortunately, inspections of the interior scroll case and pressure taps of each facility were not available as part of this study. Inspections should include an assessment of the condition of the individual taps, local coatings along the scroll case wall, or other geometric changes that could influence pressure at the taps. These may include wear, coating damage, corrosion, welding, or other surface flaws or irregularities. Dirty or clogged areas of the intake trash rack, degraded coatings or increased penstock roughness may have influenced the WK calibration. Larger scale modifications to the intake, penstock, scroll case, or turbine runner that could alter the flow distribution at the pressure taps could also affect the WK flow

measurements, although these did not occur to any of the units that were included as part of this study. Any changes to or near the pressure taps will warrant a new test to reestablish flow coefficients.

Given the age of the units (including intakes, penstocks, and scroll cases), pressure taps, and calibration data themselves (e.g., 40 years for Grand Coulee Powerplant and 54 years for Yellowtail Powerplant), a physical change affecting the pressure measurements is plausible. Inspections and potential maintenance or repairs to the pressure taps may have been sufficient to maintain accurate flow predictions with the original calibrations. However, there are no known intermittent test results or documentation available since their initial installation to verify this assumption.

Some practical considerations for WK taps and differential pressure measurement are included in the Grand Coulee Powerplant recalibration report provided in appendix B.

## 5.0 Conclusions

The Winter-Kennedy flow measurement method was evaluated for modern day application to Reclamation hydropower facilities by comparing field test results of WK discharge estimates from original calibrations to absolute discharge measurements. Six different tap configurations on three different units and facilities were tested. Differences in discharge varied from about 3% to over 10% depending on the tap configuration and flow rate. In general, percent differences were greatest at low flows and then improved as the flow rate increased. Unfortunately, access inside each unit's scroll case was unavailable to inspect the condition of the pressure taps and coatings of the penstock and scroll case and thus the actual reasons for differences could not be determined. Since the installation and original calibrations of the pressure taps ranged from 40 to 54 years, it is plausible that changes to the coating or scroll case wall near the pressure taps have occurred and influenced the pressure differential and resulting calibration and discharge.

Results indicate that application of original Winter-Kennedy equations to a Reclamation hydropower unit may produce discharge measurements that are accurate within approximately  $\pm 10\%$ . However, new calibrations of Winter-Kennedy taps can be accurate to less than 1% assuming that the system is maintained and there are no changes to the system geometry or pipe wall near the pressure taps. A test for each individual unit is required to obtain a new calibration. To determine the best flow measurement option for each facility, the cost of a recalibration test and maintenance for WK will need to be compared to the cost of installation and maintenance of an absolute flow measurement system.

Grand Coulee Powerplant, which was recalibrated in 2023, is a good example of how WK can be used as a reliable secondary flow measurement method in case of an outage or failure of the primary ultrasonic system. While still not able to be used for official efficiency testing, WK can be a reliable method to monitor relative unit efficiency changes, identify potential operational issues, and provide reliable discharge monitoring over time.

## 6.0 References

- Almquist, C.W., Taylor, J.W., and Walsh, J.T. 2011. Kootenay Canal Flow Rate Measurement Comparison Test Using Intake Methods. *HydroVision*.
- American Society of Mechanical Engineers (ASME). 2010. Performance Test Codes: Pressure Measurement - Instruments and Apparatus Supplement (PTC 19.2-2010). American Society of Mechanical Engineers, New York.
- . 2018. Performance Test Codes: Hydroturbines and Pump Turbines (PTC 18-2018). American Society of Mechanical Engineers, New York.
- Baidar, B., Nicolle, J., Trivedi, C., and Cervantes, M.J. No date. *Winter-Kennedy Method in Hydraulic Discharge Measurement: Problems and Challenges*.
- Kubitschek, J., and Heiner, B. 2016. Piezometer Plate Testing. Bureau of Reclamation, Denver, Colorado.
- Rau, T., and Eissner, M. 2014. Experience with Winter-Kennedy Coefficients on Hydraulic Identical Units. *The 10th International Conference on Hydraulic Efficiency Measurements*. Itajuba, Brazil.
- Winter, I.A., and Kennedy, A.M. 1933. Improved Type of Flow Meter for Hydraulic Turbines. *American Society of Civil Engineers* 59(4).



# **Appendix A**

Literature Review Summary



Table A-1.—Literature review summary

Author	Title and Reference	Notes
Tobias Rau and Marco Eissner	Experience with Winter-Kennedy Coefficients on Hydraulic Identical Units	<p>Can expect different results when applying Winter-Kennedy constants to identically hydraulic units. Differences in approach piping, cooling water take offs, wear at pressure taps over time, can cause differences in pressure differential and readings.</p> <p>Efficiency of two separate, but identical units compared very well with no negligible difference using Winter-Kennedy coefficients independently derived for each respective unit. When a single set of coefficients was applied to a different unit (even though identical) a significant difference in the efficiency (about 1%) resulted.</p>
Binaya Baidar et al.	Winter-Kennedy Method in Hydraulic Discharge Measurement: Problems and Challenges	<p>Explains the influence of velocity distribution on local pressure tap locations. Pressure measurements can be altered by upstream influences, local conditions, and downstream influences.</p> <p>Identifies various causes of uncertainty to pressure measurements and Winter-Kennedy flow estimates. These include corrosion or lining changes which change the roughness, <math>Re</math> and thus the <math>K</math> value. Runner replacement or refurbishment can influence from downstream. Welding, grinding, and local thermal processes cause slight geometry changes even among “identical” units. Carefully consider changes to the spiral case and runner geometry, and condition when comparing with Winter-Kennedy measurements using the original <math>K</math> and <math>n</math> variables of the equation.</p>
ASME PTC 18-2011	Hydro Turbines and Pump Turbines	<p>Performance testing code for efficiency testing of hydropower units. Appendix D provides guidance on relative, or index, flow measurement. Guidelines for differential pressure measurements, equations, and application are provided. The general Winter-Kennedy flow equation is provided, and statistical consideration is given for the flow coefficient <math>K</math> and exponent <math>n</math>.</p>
ASME PTC 19.2-2010	Pressure Measurement Instrumentation and Apparatus Supplement	<p>Performance Test Code that provides guidance for pressure measurement. The section on Measurement Installations describes pressure tap design and errors induced by local velocities. Equations and graphs are provided to reduce errors in the pressure measurement for proper sizing, design, and shape of the pressure taps.</p> <p>Pressure tap considerations are important for Winter-Kennedy evaluation as reliable pressure measurements are key for accurate flow rate estimates.</p>

## Utilizing the Winter-Kennedy Method for Hydropower Flow Measurement

Table A-1.—Literature review summary

Author	Title and Reference	Notes
Kubitschek and Heiner	Piezometer Plate Testing	<p>Plate mounted piezometer installations on the internal surfaces of a penstock have been used to measure pressures for hydropower turbine performance. A laboratory study was conducted to determine plate sizing and geometry to provide reliable static pressure measurements. Guidelines for length and transition shape were produced from this study for a range of flow velocities (10–18 ft/s) which is typical of hydropower flows.</p> <p>While not directed to Winter-Kennedy taps, results from this study highlight the sensitivity of static pressure measurements to local geometry near the piezometer taps.</p>
Almquist et al.	Kootenay Canal Flow Rate Measurement Comparison Test Using Intake Methods	<p>Winter-Kennedy flow rates were compared to several other methods for flow estimates of a Kaplan turbine with a short intake section. It had the greatest deviation from the reference flow measurement (ultrasonic) compared to the other methods being tested. The difference was greatest at the lowest test flow (3.25%) and least at the highest test flow (1.5%).</p> <p>It was based on a 1983 calibration that was performed at flow rates higher than the greatest flow rate tested during this study. Perhaps that is why there were large deviations.</p>

## **Appendix B**

Grand Coulee Dam Winter-Kennedy Test Report 2023





— BUREAU OF —  
RECLAMATION

Hydraulic Laboratory Technical Memorandum, PAP-1225

# Winter-Kennedy Flow Measurements – Units G24 and G20

Grand Coulee Nathaniel “Nat” Washington Power Plant, WA  
Columbia-Pacific Northwest Region



U.S. Department of the Interior  
Bureau of Reclamation  
Technical Service Center  
Hydraulic Investigations and Laboratory Services  
Denver, Colorado

November 2023

# Winter-Kennedy Flow Measurements – Units G24 and G20

**Grand Coulee Nathaniel “Nat” Washington Power Plant, WA  
Columbia-Pacific Northwest Region**

*prepared by*

**JOSHUA MORTENSEN** Digitally signed by JOSHUA MORTENSEN  
Date: 2023.11.15 10:18:23 -07'00'

---

Josh Mortensen, P.E.

Hydraulic Engineer, Hydraulic Investigations and Laboratory Services Group, 86-68560

*reviewed by*

**TONY WAHL** Digitally signed by TONY WAHL  
Date: 2023.11.15 12:12:33 -07'00'

---

Technical Approval: Tony Wahl, P.E.

Technical Specialist, Hydraulic Investigations and Laboratory Services Group, 86-68560

**SHANNA DURHAM** Digitally signed by SHANNA DURHAM  
Date: 2023.11.15 11:45:05 -07'00'

---

Peer Review: Shanna Durham, P.E.

Mechanical Engineer, Turbines and Pumps Group, 86-68470

# Introduction

The Hydraulic Investigations and Laboratory Services group was requested by Grand Coulee Powerplant to perform Winter-Kennedy flow measurement testing for units in the Third Powerhouse. This testing was completed in conjunction with field performance (efficiency) and cavitation testing performed by engineers from the Turbines & Pumps and Hydropower Diagnostics & SCADA Groups.

The main objective of the Winter-Kennedy (WK) testing was to determine accurate equations to provide reliable flow measurements from existing WK pressure taps on units G24 and G20. WK is a relative flow measurement method and considered secondary to the ultrasonic flow sensors (Accusonic) currently installed on the penstocks. Having a secondary method to measure discharge is valuable to provide redundancy, is relatively simple and inexpensive to maintain, and is accurate and reliable within certain limitations.

## Test Method

### Winter-Kennedy Flow Measurement Method

The “Winter-Kennedy” flow measurement method was developed by I.A. Winter and A.M. Kennedy in 1933 (Winter & Kennedy, 1933). It correlates a difference in pressure at a cross section of the scroll case to the volumetric flow rate, or discharge, through the penstock. The pressure difference is measured from taps located at different sides of the conduit, typically one or more at the top and a reference tap at the side (see Figure 1 as an example). Discharge ( $Q$ ) is correlated to the pressure difference ( $\Delta P$ ) through the relationship shown in Eq. 1 where the coefficient  $K$  and exponent  $n$  are determined through experimental testing where both  $Q$  and  $\Delta P$  are measured over a range of operating conditions. Both  $K$  and  $n$  are dependent on the geometry of the conduit and  $n$  is typically close to 0.5 (The American Society of Mechanical Engineers, 2011) but both calibration factors are unique to the unit for which they are tested.

$$Q = K(\Delta P)^n \quad \text{Eq. (1)}$$

As with any flow measurement method, the WK method has both benefits and limitations. Benefits include its simplicity and relative low cost. The pressure taps and piping are already in place for all Grand Coulee hydropower units and only require a device for measuring differential pressure. A redundant flow measurement system that can be used reliably when the primary system (Accusonic flow meter in this case) is out of service is very valuable and relatively inexpensive to setup and maintain. Limitations of this method include inaccurate flow estimates at low discharges when the pressure differential reading is small, and variation of pressure readings due to changes to the scroll case, penstock, or pressure taps. Examples of this include modifications to the intake, penstock or

scroll case geometry, wear or changes near the pressure taps (e.g., coating failure/repair, welds, grinding, etc.), or any other changes that influence the flow patterns in the conduit that affect pressure readings at the taps (Rau & Eissner, 2014).

## Unit G24

Unit G24 is one of the three large units in Grand Coulee's Third Powerhouse. The unit is rated at 805 MW and can operate in a discharge range of less than 15,000 cubic feet per second (cfs) to about 36,000 cfs depending on power needs and reservoir level. G24 has four pressure taps for WK flow measurement; three near the top of the scroll case (labeled A, B, C respectively) and the fourth used as a reference on the side of the scroll case (labeled D). Tap locations and labels are shown in Figure 1 and Figure 2.

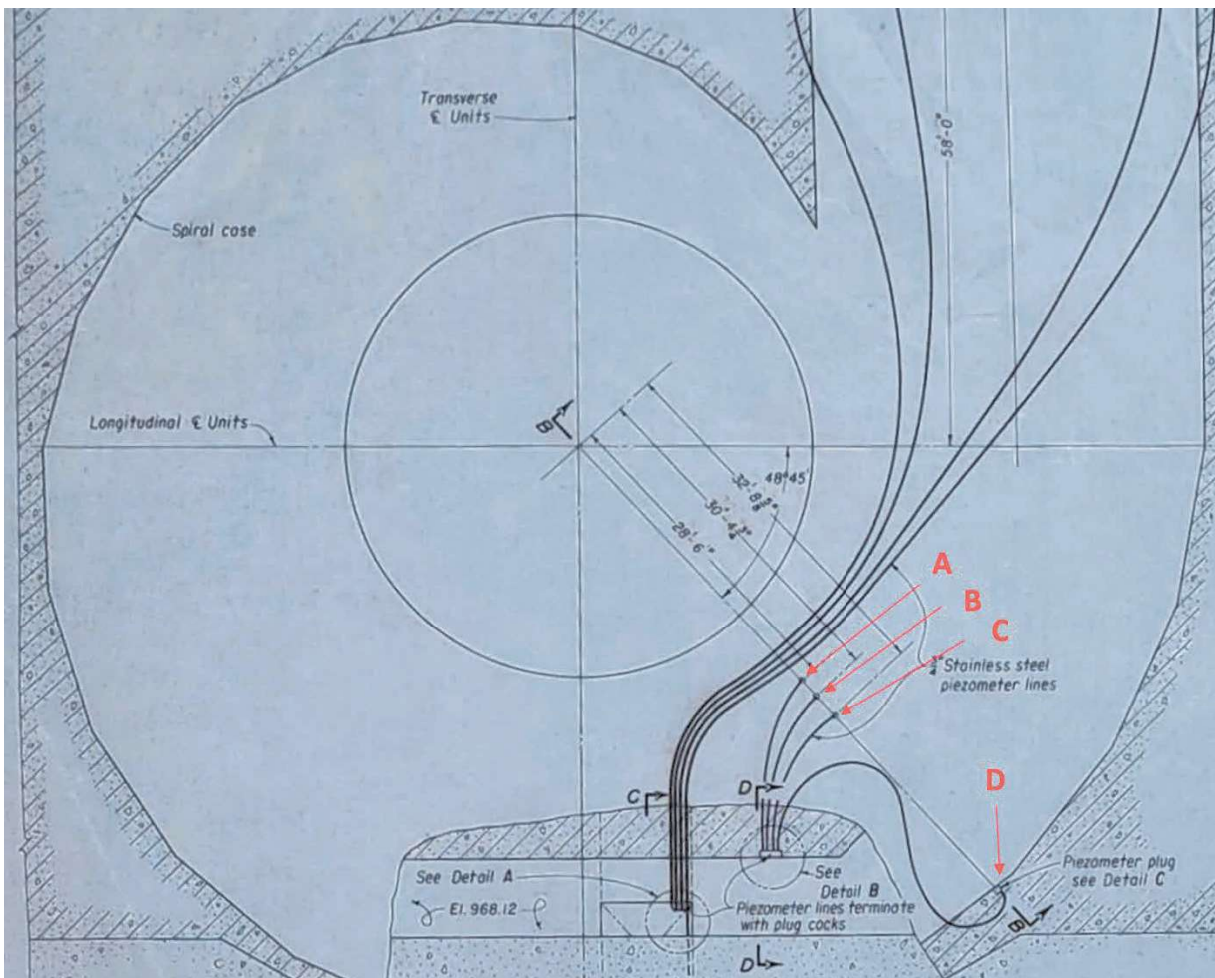

Figure 1. Plan view of WK pressure taps for unit G24 from drawing 1222-D-3686. WK tap locations are shown in red.

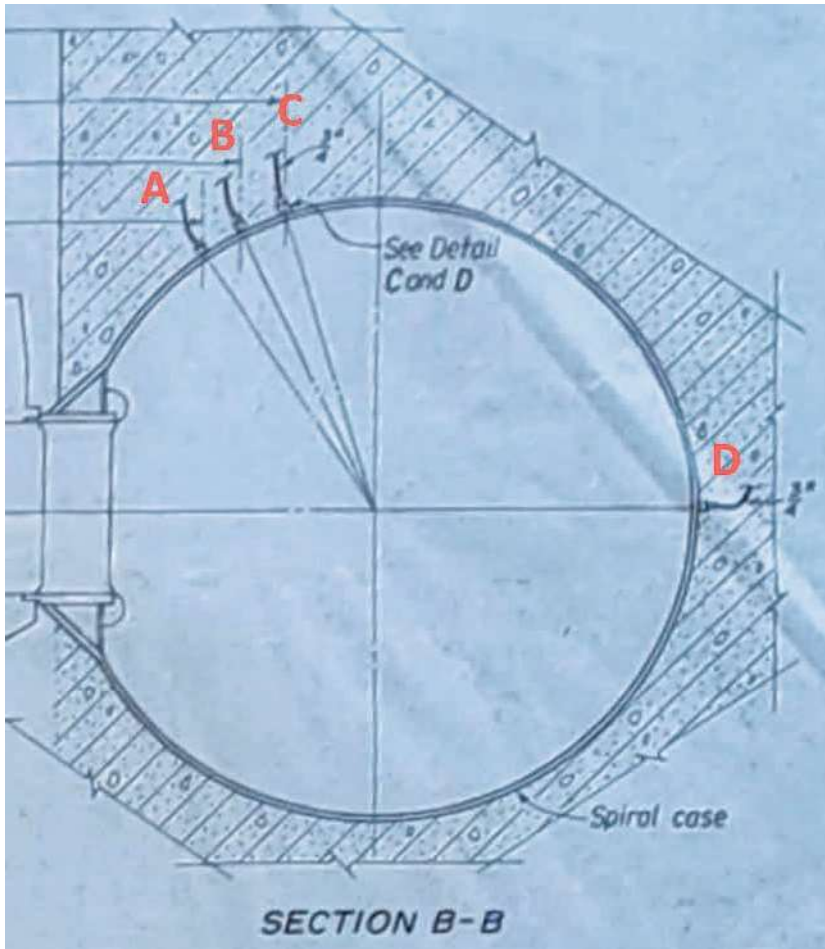

Figure 2. Cross section view of WK pressure taps for unit G24 from drawing 1222-D-3686.

Connection piping for each of the pressure taps is made of  $\frac{3}{4}$ -inch stainless steel and terminates at a single location on the main control floor (El. 968.12 ft). A piping manifold was fabricated from  $\frac{1}{4}$ -inch stainless steel tubing to connect to the differential pressure sensor and control the tap configuration to be used for measurement with an arrangement of shut off valves (Figure 3). To expedite testing, two additional temporary differential pressure sensors were used to record pressure readings simultaneously. The temporary sensors were placed on the floor and the permanent sensor is mounted to the concrete wall as shown in Figure 3. There are three options for flow measurement depending on the tap configuration. Each measures the pressure difference between a top side tap to the reference tap D on the side of the conduit (A-D, B-D, C-D). There is a unique set of  $K$  and  $n$  values for each configuration.

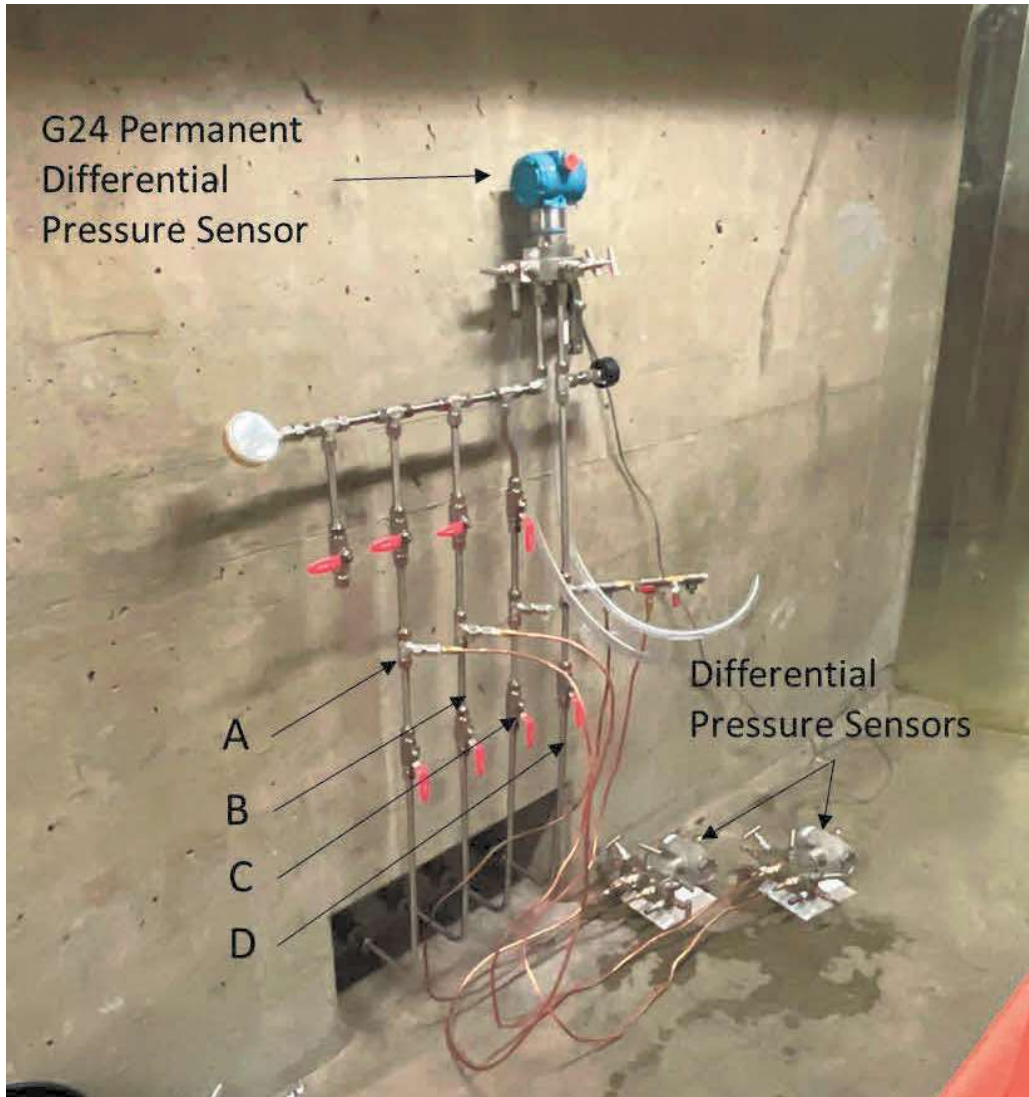

Figure 3. WK pressure tap manifold and differential pressure sensor for unit G24.

In 1983, performance testing established coefficient and exponent values for each WK pressure tap configuration on unit G24 shown in Figure 4 (Heigel, Lewey, & Favero, 1984). To our knowledge, the WK taps were never used regularly since Accusonic acoustic flow meters were installed in 2003 as the primary method for flow measurement. However, during unit efficiency and cavitation testing performed on G24 by General Electric (GE) in 2017, a discharge comparison was made to the A-D combination of the WK pressure taps. This comparison showed good agreement between the Accusonic and WK flow equation for all flows above 5,000 cfs (Figure 5). The other pressure tap configurations were not tested.

### Flow Index Calibration

Pressure differential measurements were made across the Winter-Kennedy piezometer taps using a differential mercury manometer. The Winter-Kennedy taps then were calibrated by correlating discharge to differential pressure. This correlation was made by using the method of least squares; i.e., fitting the data to the equation  $Q = CD^e$ .

For Grand Coulee Third Powerplant Unit G-24,  $C$  and  $e$  were determined to be:

Taps	$C$	$e$	$Q = CD^e$
A-D	7726.3588	0.5063	$Q = 7726.3588 D^{0.5063}$
B-D	8337.8116	0.5043	$Q = 8337.8116 D^{0.5043}$
C-D	9204.0686	0.5012	$Q = 9204.0686 D^{0.5012}$

Tabulated data and calibration curves are shown in table 12 and on figures 4, 5, and 6, respectively.

Figure 4. WK coefficient and exponents determined for each configuration from 1983 testing on G24 (Heigel, Lewey, & Favero, 1984).

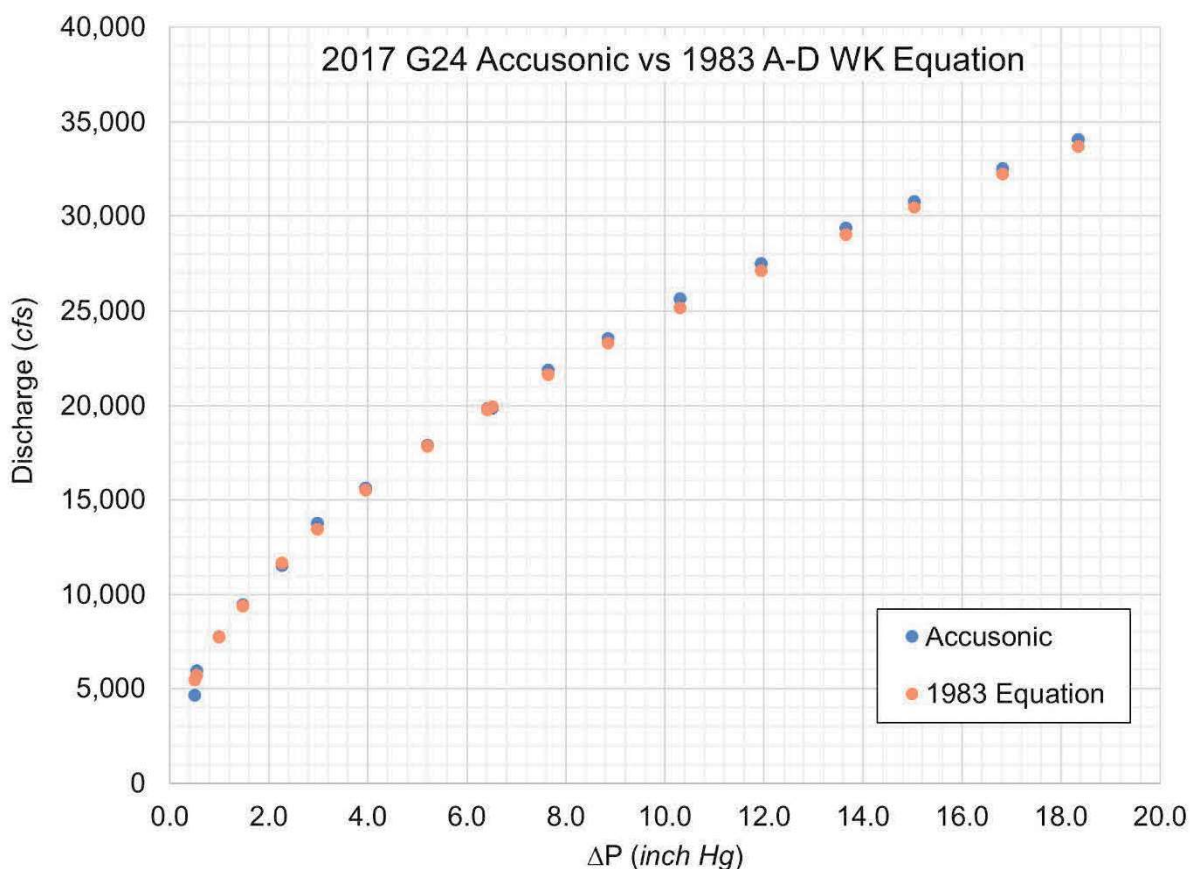

Figure 5. Comparison of GE 2017 testing using the Accusonic flow meter to the 1983 WK flow equation for taps A-D.

## Unit G20

Unit G20 is one of the three smaller units in Grand Coulee's Third Powerhouse and is rated at 690 MW and can operate in a discharge range of less than 15,000 cfs to 35,000 cfs depending on power needs and reservoir level. G20 has three pressure taps for WK flow measurement; two near the top of the scroll case (labeled A and B respectively) and the third used as a reference on the side of the scroll case (labeled C). Tap locations and labels are shown in Figure 6 and Figure 7.

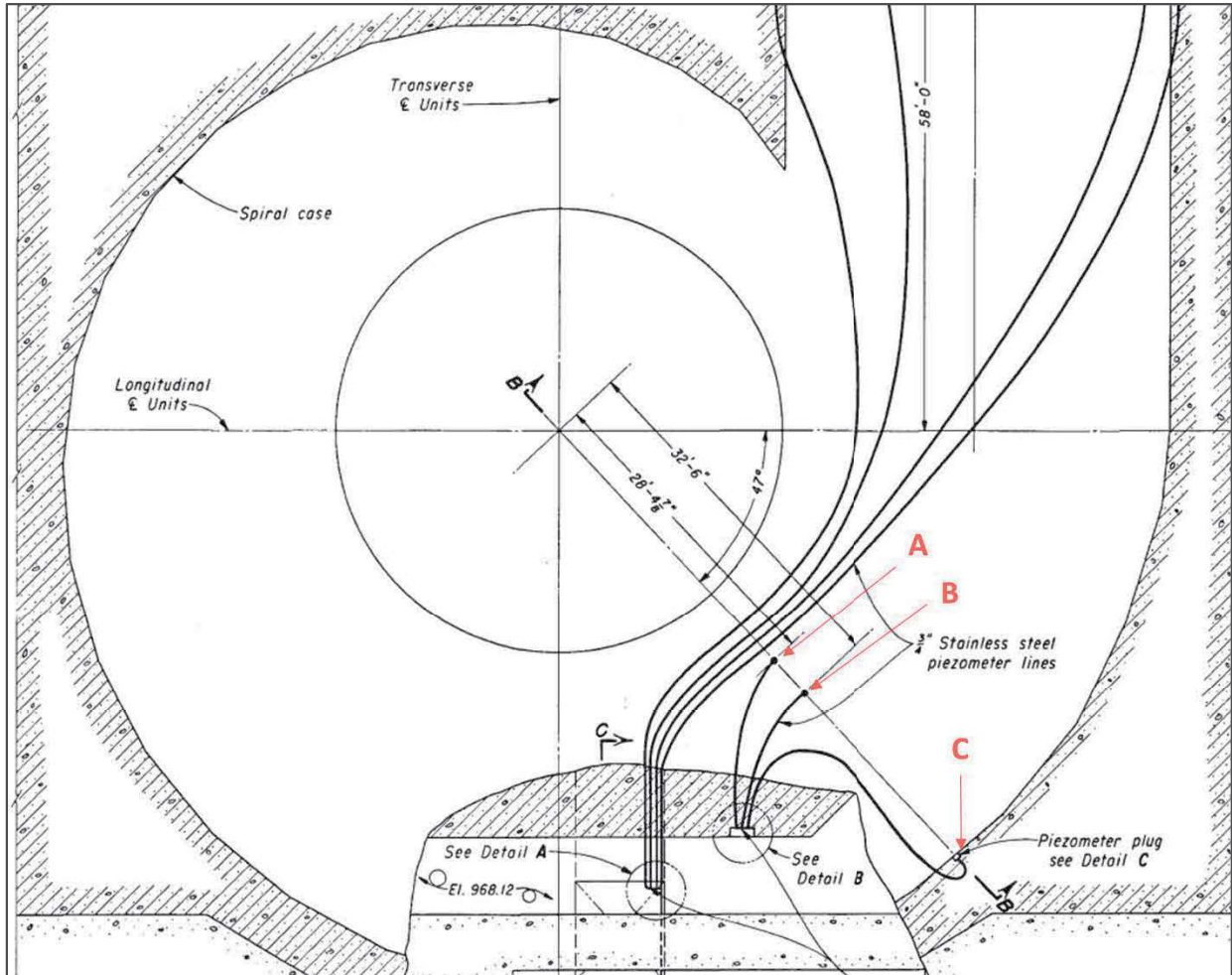

Figure 6. Plan view of WK pressure taps for unit G20 from drawing 1222-D-940.

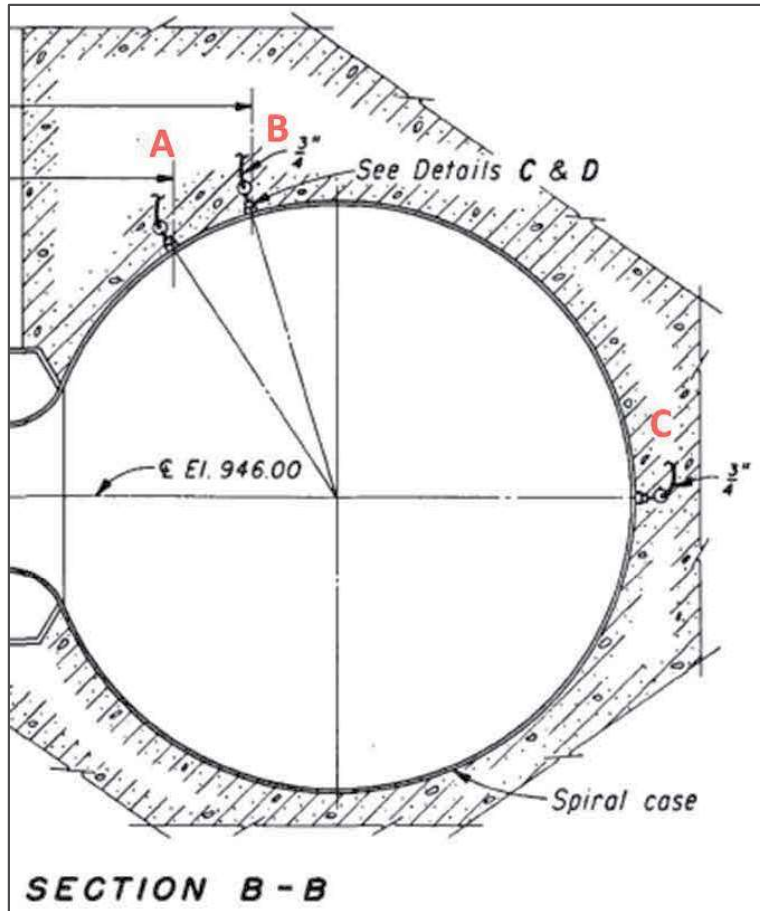

Figure 7. Cross section view of WK pressure taps for unit G20 from drawing 1222-D-940.

Also for G20, connection piping is made of  $\frac{3}{4}$ -inch stainless steel and terminates at a single location on the main control floor near the unit (El. 968.12 ft). A manifold was fabricated of  $\frac{1}{4}$ -inch stainless steel tubing to connect to the differential pressure sensor and control the tap configuration to be used for measurement with an arrangement of shut off valves (Figure 8). There are two options for flow measurement depending on the tap configuration. Each measures the pressure difference between a top side tap to the reference tap C on the side of the conduit (A-C and B-C). There is a unique set of  $K$  and  $n$  values for each configuration.

Documentation of WK original testing and determination of the  $K$  and  $n$  values for G20 has not been found. An important goal of this testing was to establish these values for G20 to be used in the future.

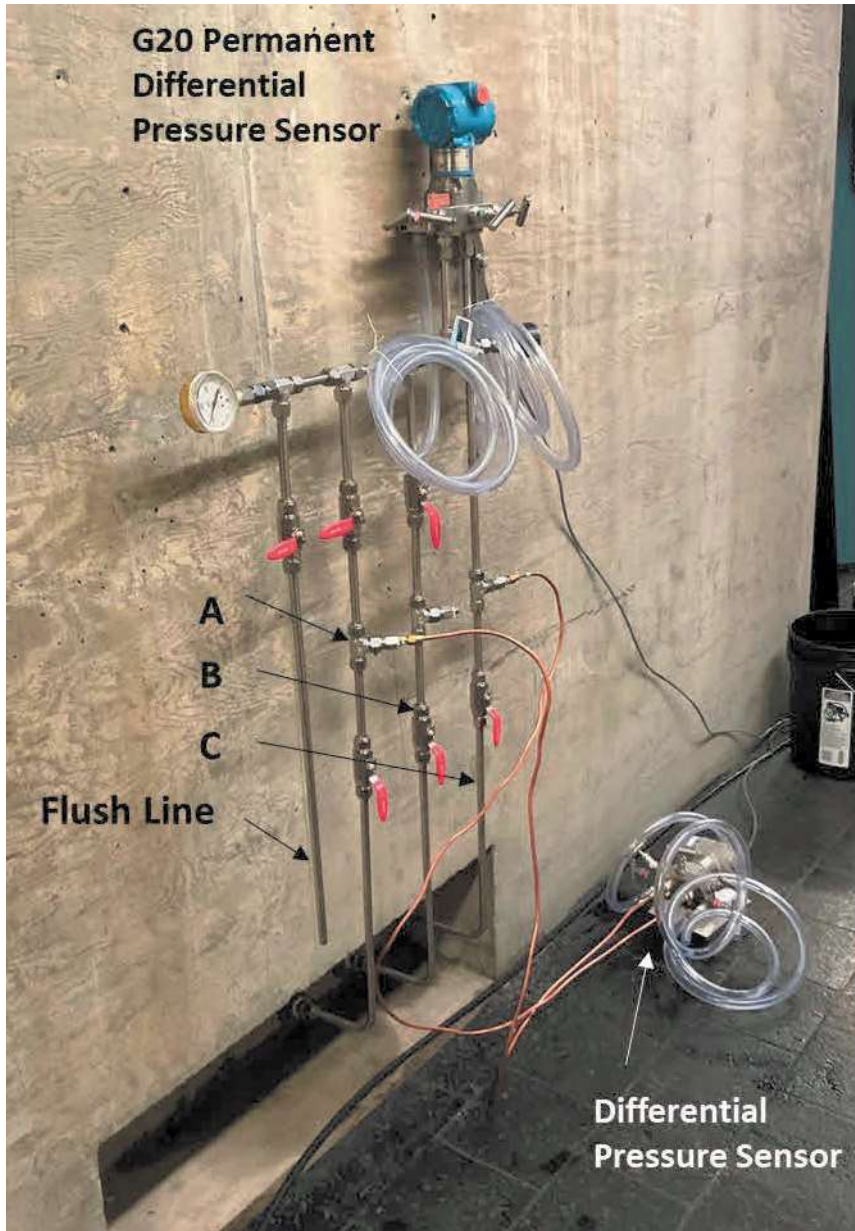

Figure 8. WK pressure tap manifold and differential pressure sensor for unit G20.

## Test Setup and Data Acquisition

WK testing was performed simultaneously with unit efficiency and cavitation testing for both G24 and G20. Differential pressure transducers and 8-path Accusonic acoustic flow meters were the primary instruments used as outlined in Table 1. Three independent differential pressure sensors were used to capture pressure readings from all WK tap configurations simultaneously during the test period.

For each test run the discharge and power output were allowed to stabilize and then data were recorded over a 7-minute period. Differential pressure readings were recorded at 1 sample per

second and Accusonic flow rate measurements were recorded at the maximum refresh rate of the meter at each unit (about 82 samples per test for G24 and about 292 samples per test for G20). Differences in refresh rate were due to limitations of the Accusonic equipment on each unit.

Table 1. Instrumentation used for WK flow measurement testing for G24 and G20.

GC Unit	Measurement	Instrument	Range	Accuracy	Type	Sample Rate
G24	A-D WK taps	$\Delta$ P Sensor (temporary)	0-15 psi	0.1% FS	Rosemount 3051	1 sample / second
	B-D WK taps	$\Delta$ P Sensor (temporary)	0-36 psi	0.1% FS	Rosemount 3051	1 sample / second
	C-D WK taps	$\Delta$ P Sensor (permanent)	0-36 psi	0.1% FS	Rosemount 3051	1 sample / second
	Penstock Discharge	Acoustic Flow meter	-	1.0%	Accusonic	82 samples / 7 min
G20	B-D WK taps	$\Delta$ P Sensor (temporary)	0-15 psi	0.1% FS	Rosemount 3051	1 sample / second
	C-D WK taps	$\Delta$ P Sensor (permanent)	0-36 psi	0.1% FS	Rosemount 3051	1 sample / second
	Penstock Discharge	Acoustic Flow meter	-	0.60%	Accusonic	292 samples / 7 min

Differential pressure data were collected from a 4-20mA output signal from the sensor into an Analog to Digital converter and recorded on a laptop computer (Figure 9). A Measurement Computing 1604-HS DAQ hardware device with 16-bit resolution and DasyLab 16.0 software were used to process, scale, and record differential pressure measurements from each WK tap configuration. Each differential pressure sensor was calibrated on site prior to testing to accurately scale the output signals.

Accusonic discharge measurements were recorded by engineers from the Turbines and Pumps Group using AccuFlow software on a laptop computer connected to the Accusonic 8510+. Velocities for each acoustic path were recorded and used with the local area of the penstock in postprocessing to determine the volumetric flow rate.



Figure 9. Data Acquisition setup used for WK testing for units G24 and G20.

## Uncertainty Analysis

The uncertainty for each WK pressure tap configuration was estimated for the discharge predicted from the respective WK flow equation (Eq. 1) as determined from field measurements. The approach used to estimate the uncertainty is explained in detail in (Coleman & Steele, 1999). For purposes of this technical memo, a general description is described here.

First, the systematic uncertainty of the coefficient  $K$  was estimated from uncertainties associated with the differential pressure and Accusonic discharge measurements using Eq. 2. It was assumed that there is no uncertainty associated with the exponent  $n$ .

$$U_K = \left[ \left( \frac{\partial K}{\partial \Delta P} \right)^2 U_{\Delta P}^2 + \left( \frac{\partial K}{\partial Q} \right)^2 U_Q^2 \right]^{1/2} \quad \text{Eq. 2}$$

Next, the systematic uncertainty of the WK discharge was estimated from the uncertainty associated with  $K$  established during testing and the differential pressure measurement (Eq. 3). The random uncertainty of the WK discharge was estimated by Eq. 4 for differential pressure measurements, which was then used with the systematic uncertainty in Eq. 5 to determine the total uncertainty of the WK discharge measurement.

$$U_{Q_{wk}} = \left[ \left( \frac{\partial Q_{wk}}{\partial K} \right)^2 U_K^2 + \left( \frac{\partial Q_{wk}}{\partial \Delta P} \right)^2 U_{\Delta P}^2 \right]^{1/2} \quad \text{Eq. 3}$$

$$U_{random} = \frac{t(S_d)}{no^{1/2} Avg} \quad \text{Eq. 4}$$

$$U_{total} = \left[ U_{Q_{wk}}^2 + U_{random}^2 \right]^{1/2} \quad \text{Eq. 5}$$

Symbols for equations 2 through 5 are defined as:

- $K$  = coefficient for WK discharge equation 1 (-)
- $\Delta P$  = differential pressure measurement (inch Hg)
- $Q$  = Accusonic discharge measurement (cfs)
- $Q_{wk}$  = Discharge from WK equation 1. (cfs)
- $t$  = Student's t coefficient for the 95% confidence level, assumed to be 2 (-)
- $S_d$  = standard deviation of measurements recorded over the test period (inch Hg)
- $no$  = number of measurements recorded over the test period
- $Avg$  = mean of measurements recorded over the test period (inch Hg)

## Results and Analysis

### Unit G24

Testing was completed for all three WK pressure tap configurations for G24 over a range of operating conditions. The resulting coefficients, exponents, data correlation values, and total uncertainties for each configuration are summarized in Table 2. These  $K$  and  $n$  values replace those from 1983 testing and are to be used for future WK flow measurements. These values were adjusted manually to optimize the curve fit visually and produce the highest  $R^2$  result possible for flows greater than 12,000 cfs.  $R^2$  values near 1 show a strong correlation between the Accusonic discharge and differential pressure measurements. The total uncertainties for discharge estimated from the WK equation are near 1% and apply to all flows greater than 12,000 cfs. WK flow estimates below this discharge will provide inaccurate flow results. Uncertainties remain valid assuming there is no change within the penstock, scroll case, or pressure taps that would influence the differential pressure reading.

In postprocessing of the Accusonic velocities for each path, data from Path 4 were removed and not used in the discharge calculation due to a malfunction with its transducer or cabling. This produced a measurement accuracy of 1.0% which is an improvement compared to a result that would have included the bad data from Path 4. Still, this is worse than the typical uncertainty of Accusonic flow meters of 0.5% when all 8 paths function properly.

Table 2. Unit G24 coefficients, exponents, correlations, and uncertainty

Pressure Taps	<i>K</i>	<i>n</i>	<i>R</i> <sup>2</sup>	Uncertainty
A-D	8680.0	0.4760	0.955	1.04%
B-D	9090.0	0.4850	0.955	1.04%
C-D	10,257	0.4790	0.952	1.04%

Discharge and differential pressure readings for G24 testing are shown in Table 3 including notes about air injection at the turbine runner which was an important component for concurrent efficiency and cavitation testing. Test data are also plotted in Figure 10 through Figure 13 to show the newly calibrated WK flow curves/equations compared to the discharges measured with the Accusonic meters. There is good agreement for discharges greater than about 12,000 cfs.

These figures also compare the new calibrations to those established in 1983 for all three tap configurations. Discharge estimates using the 1983 calibrations do not agree well with current test results as they are about 3% - 8% lower depending on the flow rate. This difference is curious given the good agreement to GE's test results from 2017 (previously shown in Figure 5). One explanation may be that the 2017 Accusonic discharge measurements included Path 4 in the result which was also bad at that time and was not removed in postprocessing. Another explanation may be wear or damage near the pressure taps that could have altered the pressure measurements. This is possible as spot repairs were done to the coating in the scroll case and penstock as part of a G24 overhaul in 2014 which may have affected the WK pressure taps. Finally, the 1983 WK calibrations were based on pressure-time (Gibson method) discharge measurements, which have been known to indicate lower than actual flow rates.

Table 3. Discharge and pressure differential readings from unit G24 testing.

Test #	Accusonic Flow Meter	WK ΔP			Notes
		A-D	B-D	C-D	
-	<i>cfs</i>	<i>inch Hg</i>			-
5	5,317	0.19	0.14	0.01	No air
6	5,327	0.19	0.14	0.01	Air on thru inlet
7	8,876	0.97	0.82	0.57	No air
8	8,860	0.98	0.81	0.55	Air on thru inlet
9	10,818	1.53	1.32	0.99	No air
10	10,832	1.57	1.37	1.03	Air on thru inlet
11	12,906	2.33	2.05	1.59	No air, unit getting louder
12	12,882	2.26	1.98	1.54	air thru inlet
13	12,905	2.29	2.02	1.57	air thru cone
14	14,807	3.12	2.76	2.18	no air
15	14,806	3.08	2.69	2.12	air thru cone
16	14,764	3.13	2.66	2.05	air thru inlet
17	18,938	5.25	4.50	3.55	no air
18	18,946	5.27	4.55	3.61	air thru cone
19	22,859	7.76	6.70	5.36	no air
20	22,801	7.75	6.69	5.33	air thru cone
21	24,728	9.14	7.90	6.34	no air

Test #	Accusonic Flow Meter	WK $\Delta P$			Notes
		A-D	B-D	C-D	
-	cfs	inch Hg			-
22	24,762	9.15	7.91	6.32	air thru cone
23	25,655	9.81	8.48	6.79	no air
24	25,678	9.89	8.54	6.83	air thru cone
25	26,729	10.66	9.25	7.42	no air, occasional banging and vibrations
26	26,719	10.70	9.26	7.41	air thru cone, banging significantly reduced
27	30,495	13.83	12.07	9.77	no air
28	30,370	13.88	12.07	9.73	air thru cone
29	31,872	15.26	13.22	10.68	No air
30	31,825	15.14	13.22	10.74	air thru cone
31	33,204	16.55	14.51	11.76	no air
32	34,639	18.06	15.78	12.79	no air

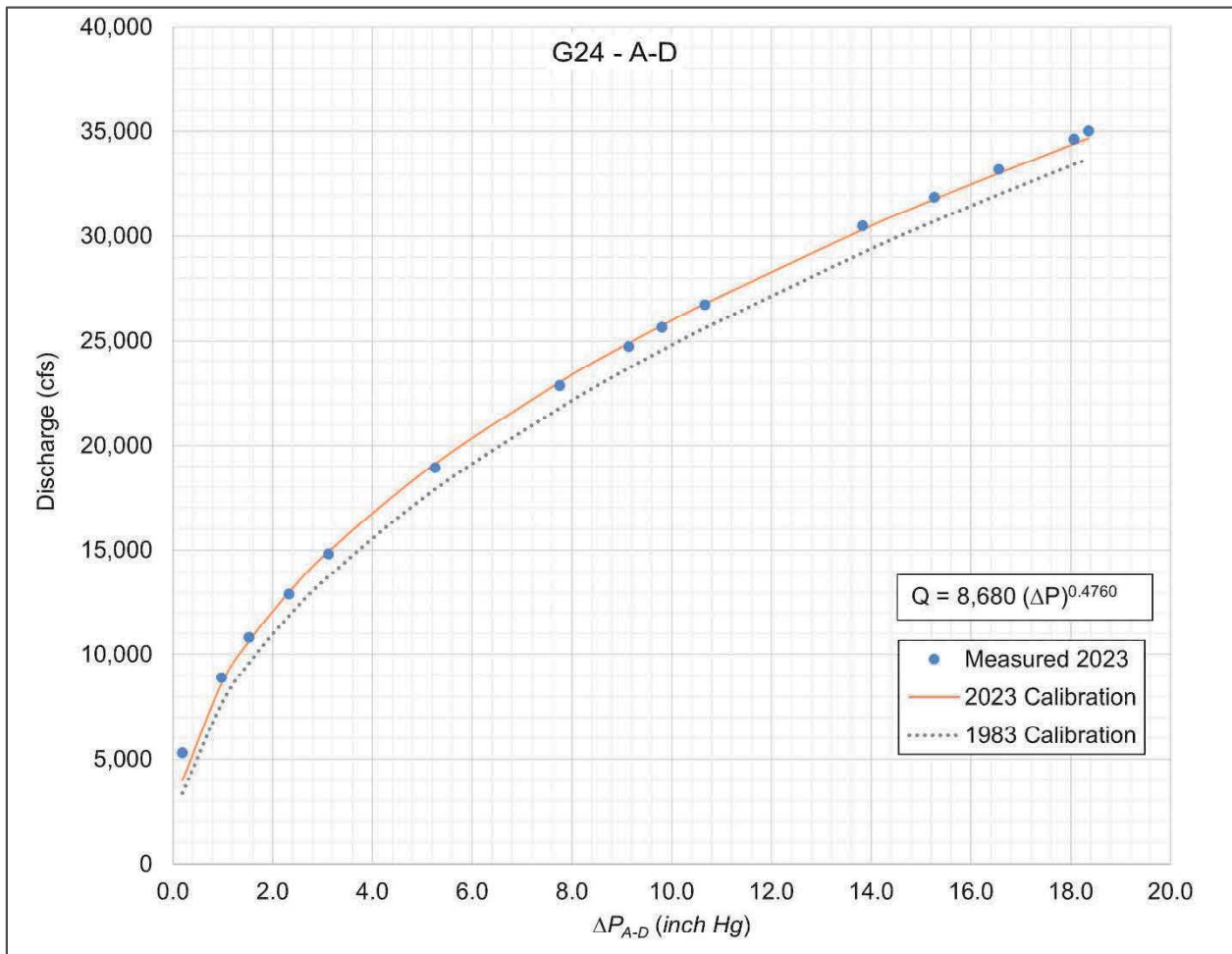

Figure 10. Plot of G24 measured discharge vs. WK configuration A-D differential pressures, with new 2023 calibration curve and old 1983 calibration.

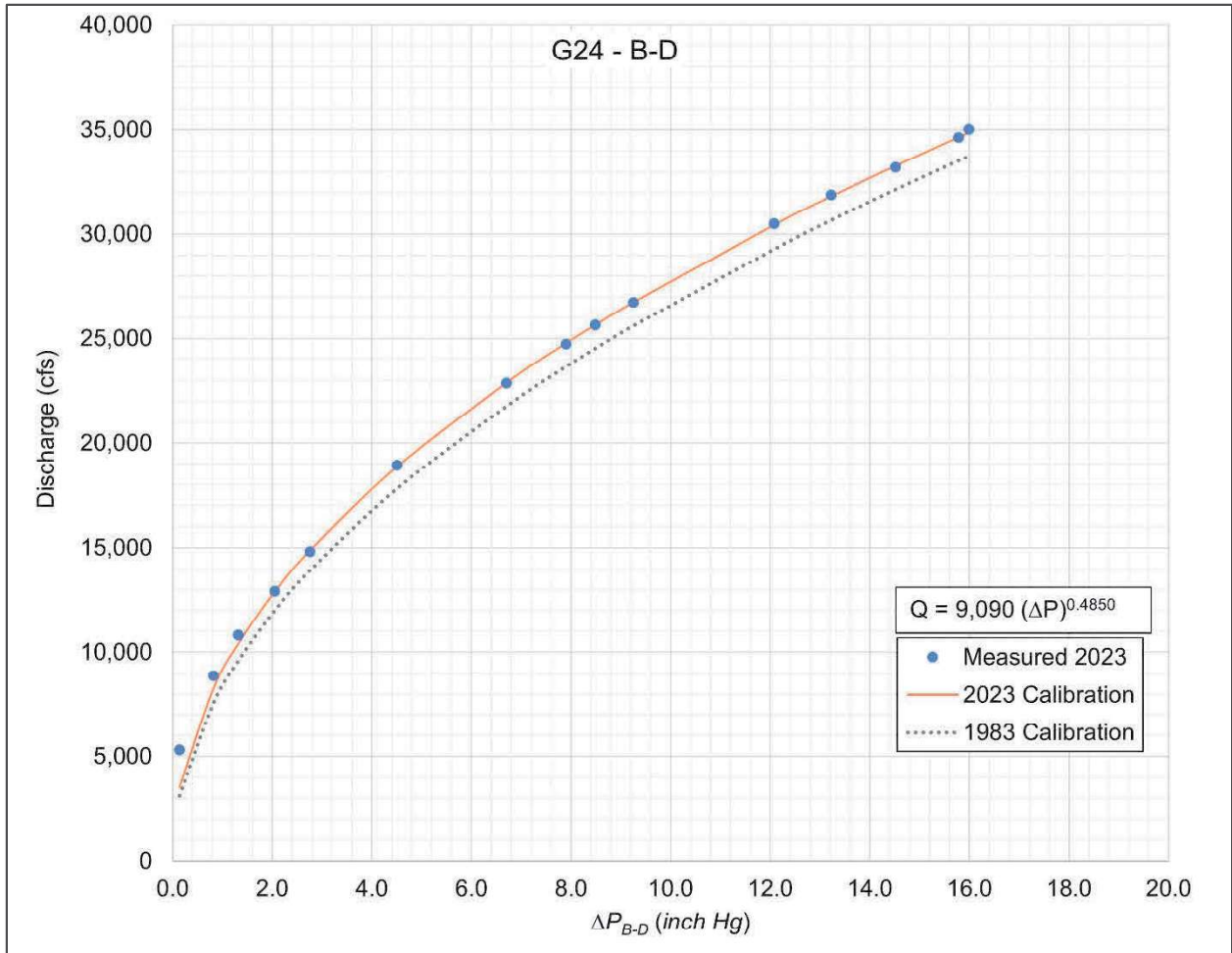

Figure 11. Plot of discharge vs. G24 configuration B-D differential pressures comparing measured data and calibrated data from 2023 testing to the 1983 calibration.

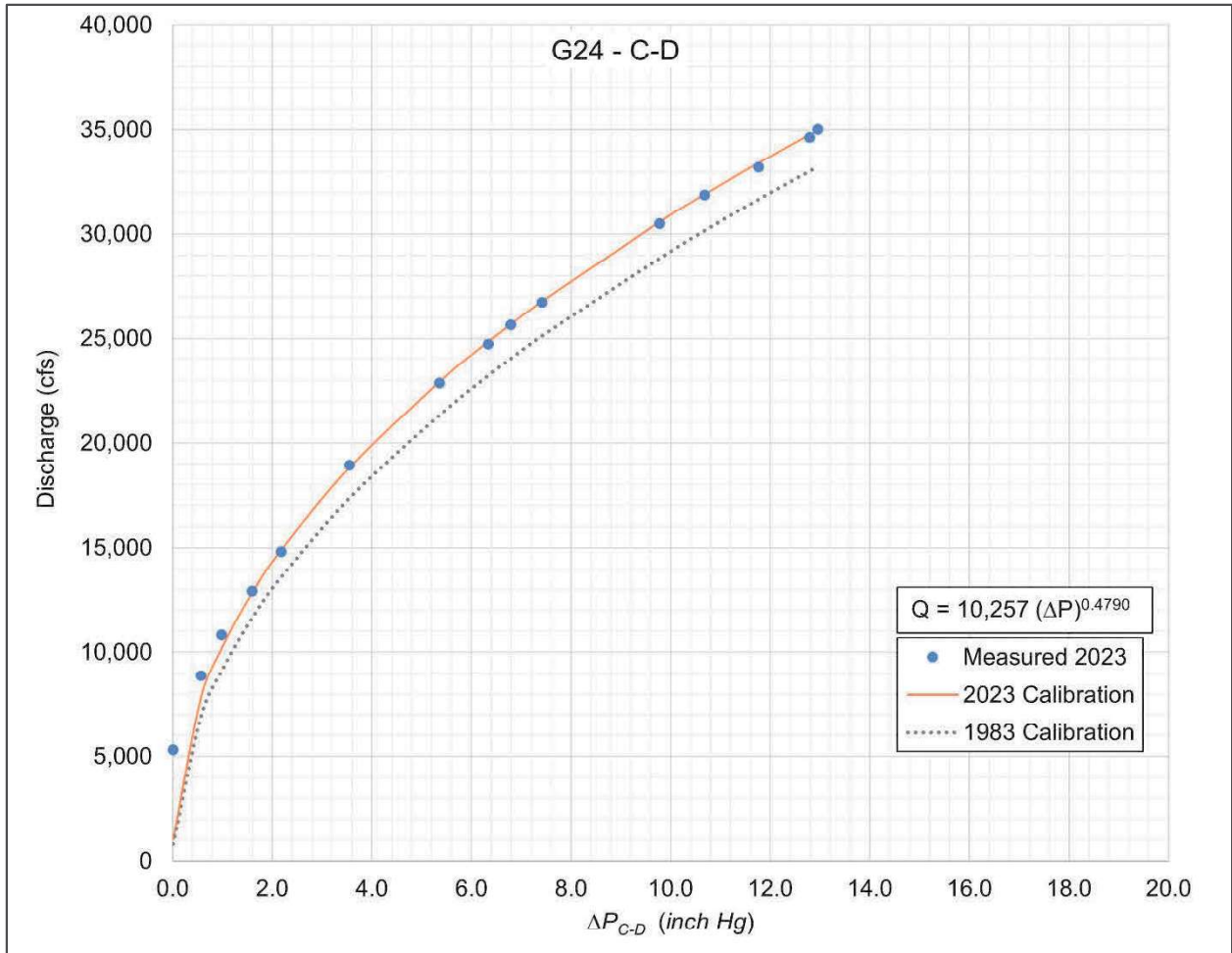

Figure 12. Plot of discharge vs. G24 configuration C-D differential pressures comparing measured data and calibrated data from 2023 testing to the 1983 calibration.

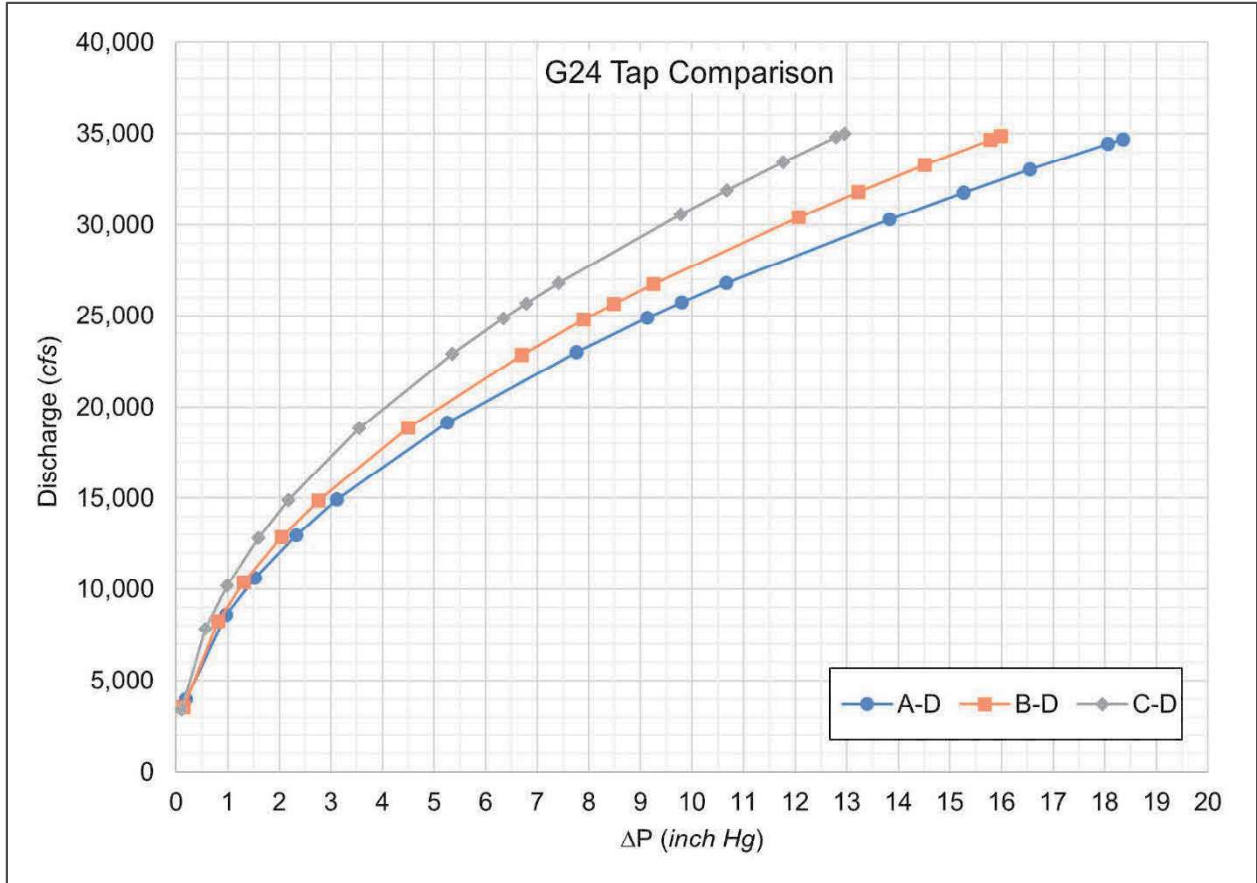

Figure 13. Plot of discharge vs. G24 differential pressures comparing 2023 calibrated data from all three WK pressure tap configurations.

## Unit G20

Testing was completed for both WK pressure tap configurations for G20 over a range of operating conditions. The resulting coefficients, exponents, data correlation values, and total uncertainties for each configuration are summarized in Table 4. These  $K$  and  $n$  values are to be used for future WK flow measurements. These values were adjusted manually to optimize the curve fit visually and produce the highest  $R^2$  result possible for flows greater than 7,000 cfs. The  $R^2$  values near 1 show a strong correlation between the Accusonic discharge and differential pressure measurements. The total uncertainties for discharge estimated from the WK equation are near 0.6% and apply to all flows greater than 7,000 cfs. WK flow estimates below this discharge will provide inaccurate flow results. Uncertainties remain valid assuming there is no change within the penstock, scroll case, or pressure taps that would influence the differential pressure reading.

For G20 Path 3 velocities were removed during postprocessing, also due to a malfunction, but resulted in an Accusonic uncertainty of 0.6%. This is better than the estimate error of 1.0% from G24 due to the path location, more stable flow condition, and a faster refresh rate of the equipment on G20. When combined with uncertainty from the WK pressure measurements this produced an uncertainty of about 0.65% for WK flow estimates.

Table 4. Unit G20 coefficients, exponents, and uncertainty.

<b>Pressure Taps</b>	<b>K</b>	<b>n</b>	<b>R<sup>2</sup></b>	<b>Uncertainty</b>
A-C	8923.0	0.4775	0.949	0.64%
B-C	9810.0	0.4950	0.961	0.66%

Discharge and differential pressure readings for G20 testing are shown in Table 5, including notes about air injection at the turbine runner which was an important component for concurrent efficiency and cavitation testing. Test data are also presented in Figure 14 through Figure 16 to show the measured flows in comparison to the new WK calibration curves and equations. The new calibration agrees well for measured discharges greater than about 7,000 cfs.

Table 5. Discharge and pressure differential readings from unit G20 testing.

Test #	Accusonic Flow Meter	WK $\Delta P$		Notes
		A-C	B-C	
-	<i>cfs</i>	<i>inch Hg</i>	<i>inch Hg</i>	-
1	32,636	15.06	11.30	No air, flow reading went over range - need to repeat test
2	32,643	15.12	11.36	repeat of test 1
3	30,411	13.10	9.88	no air
4	30,368	12.91	9.80	air thru cone
5	29,180	11.89	9.01	no air
6	29,166	11.95	9.02	air thru runner band
7	27,901	10.80	8.20	no air
8	27,826	10.79	8.23	air thru cone
9	26,514	9.76	7.44	no air
10	26,482	9.65	7.37	air thru runner band
11	25,051	8.69	6.59	no air
12	25,035	8.67	6.65	air thru cone
13	23,418	7.54	5.75	no air
14	23,402	7.54	5.77	air thru runner band
15	21,556	6.31	4.85	no air
16	21,524	6.38	4.92	air thru cone
17	17,855	4.30	3.38	no air
18	17,842	4.27	3.36	air thru runner band
19	13,929	2.53	2.05	no air
20	13,865	2.49	2.04	air thru cone
21	9,819	1.14	1.00	no air
22	9,796	1.14	1.00	air thru runner band
23	9,929	1.18	1.03	air thru cone, extra test
24	6,489	0.38	0.42	no air, scatter in channel 1 (B-C tap)
25	6,559	0.39	0.44	air thru cone, scatter of B-C decreased some with air
26	4,913	0.12	0.22	no air

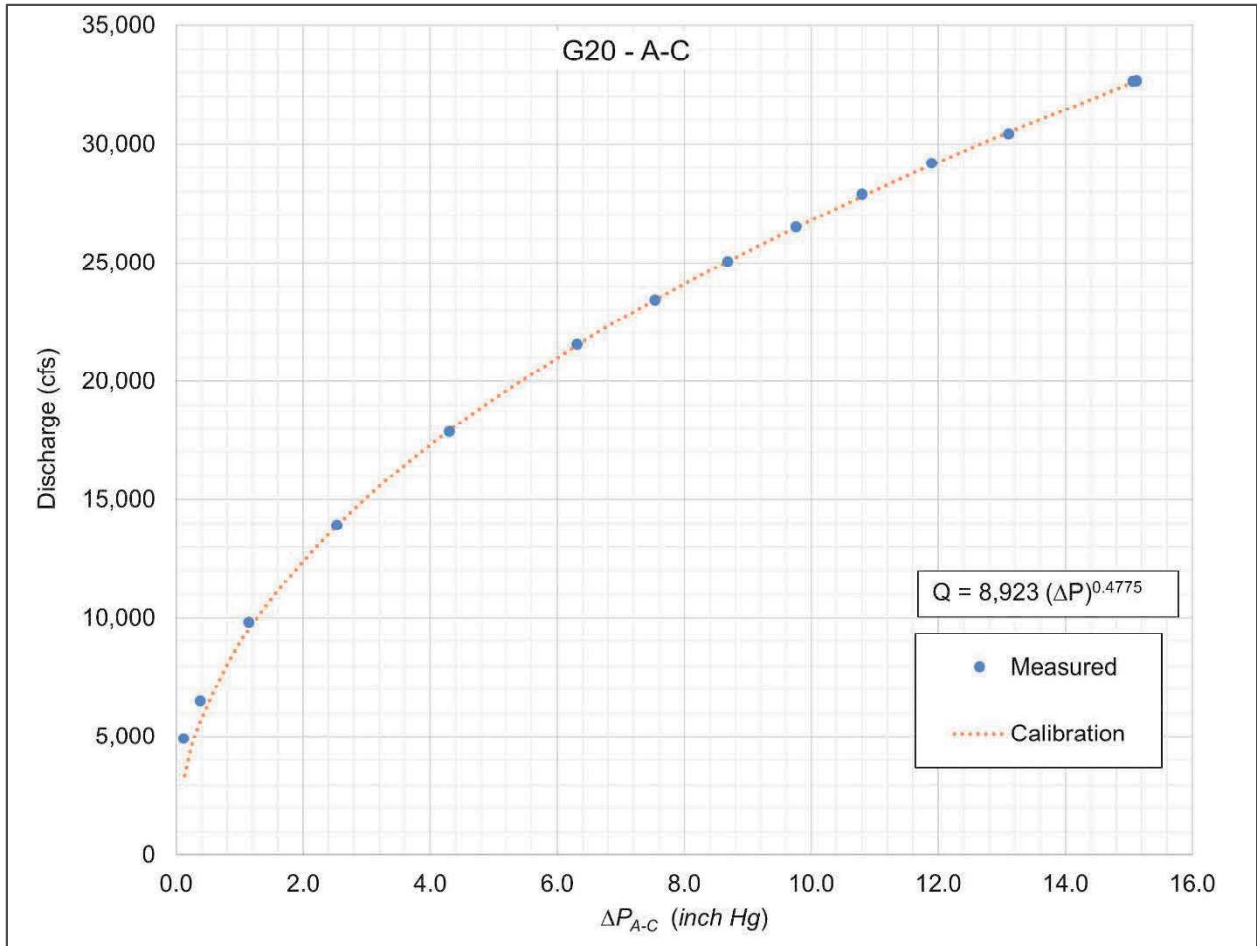

Figure 14. Plot of G20 measured discharge vs.  $\Delta P_{A-C}$  differential pressures and new WK calibration curve.

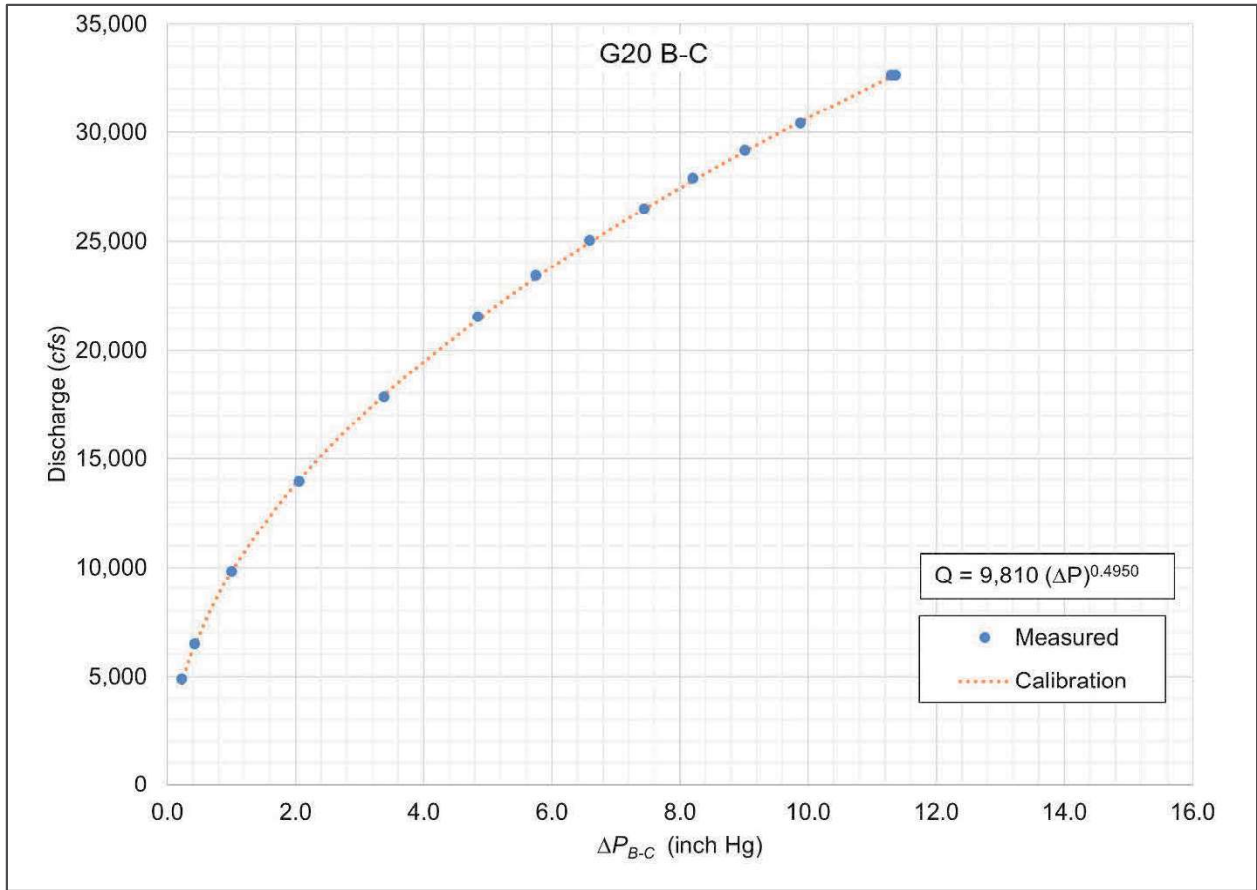

Figure 15. Plot of G20 measured discharge vs.  $\Delta P_{B-C}$  differential pressures and new WK calibration curve.

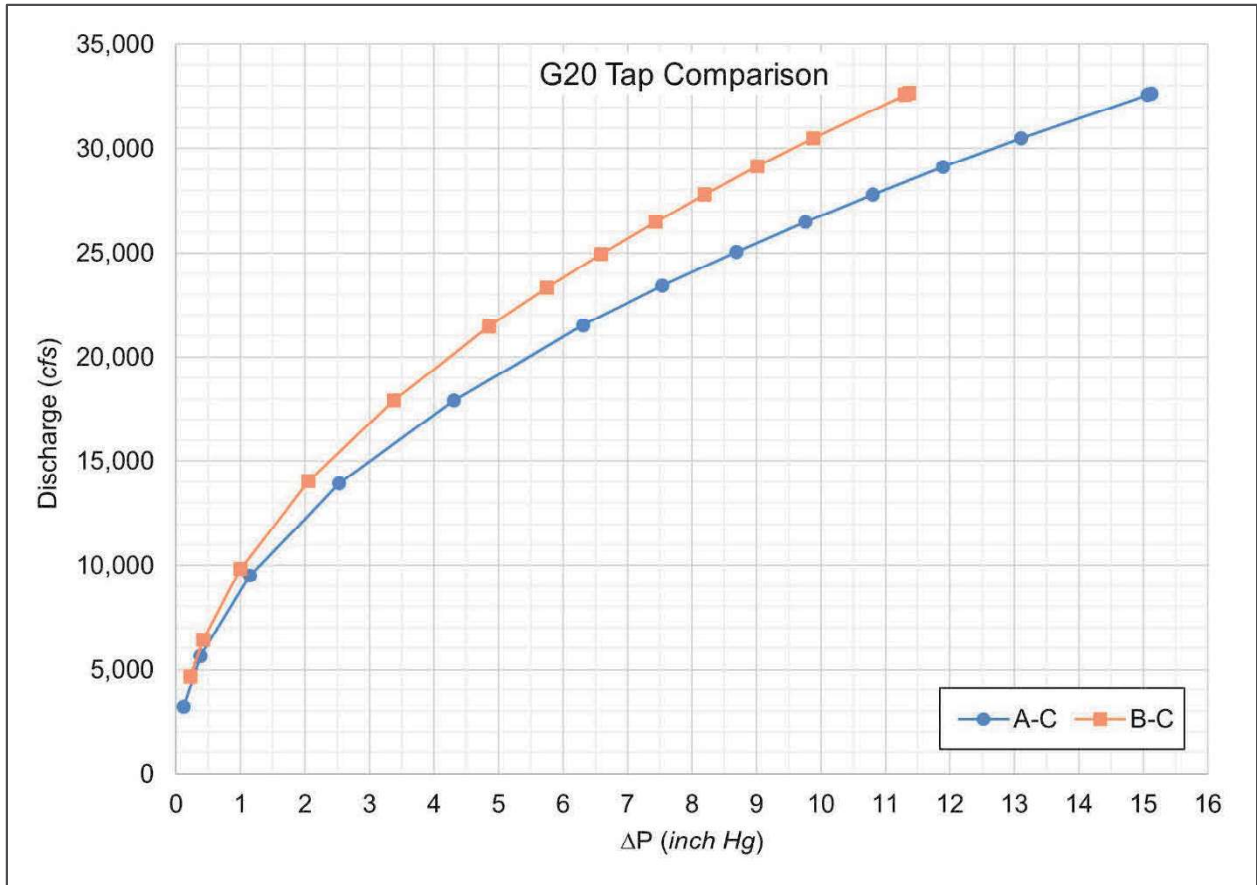

Figure 16. Plot of discharge vs. G20 differential pressures comparing 2023 calibrated data from both WK pressure tap configurations.

## Air Injection Effects

For both G24 and G20, air injection at the turbine runner is commonly used to reduce problems with rough operation (draft tube surging) at partial load. Air injection had negligible effects on WK flow measurements. This is shown by the direct comparison of WK flow estimates without air to those with air in Figure 17 and Figure 18 for all pressure tap configurations of both G24 and G20, respectively. Differences were less than 2% for both units, and there is no consistent difference related to the air injection location. This result was expected since the points of air injection are far downstream from the WK pressure taps. Future use of air injection should not hinder accurate flow measurement.

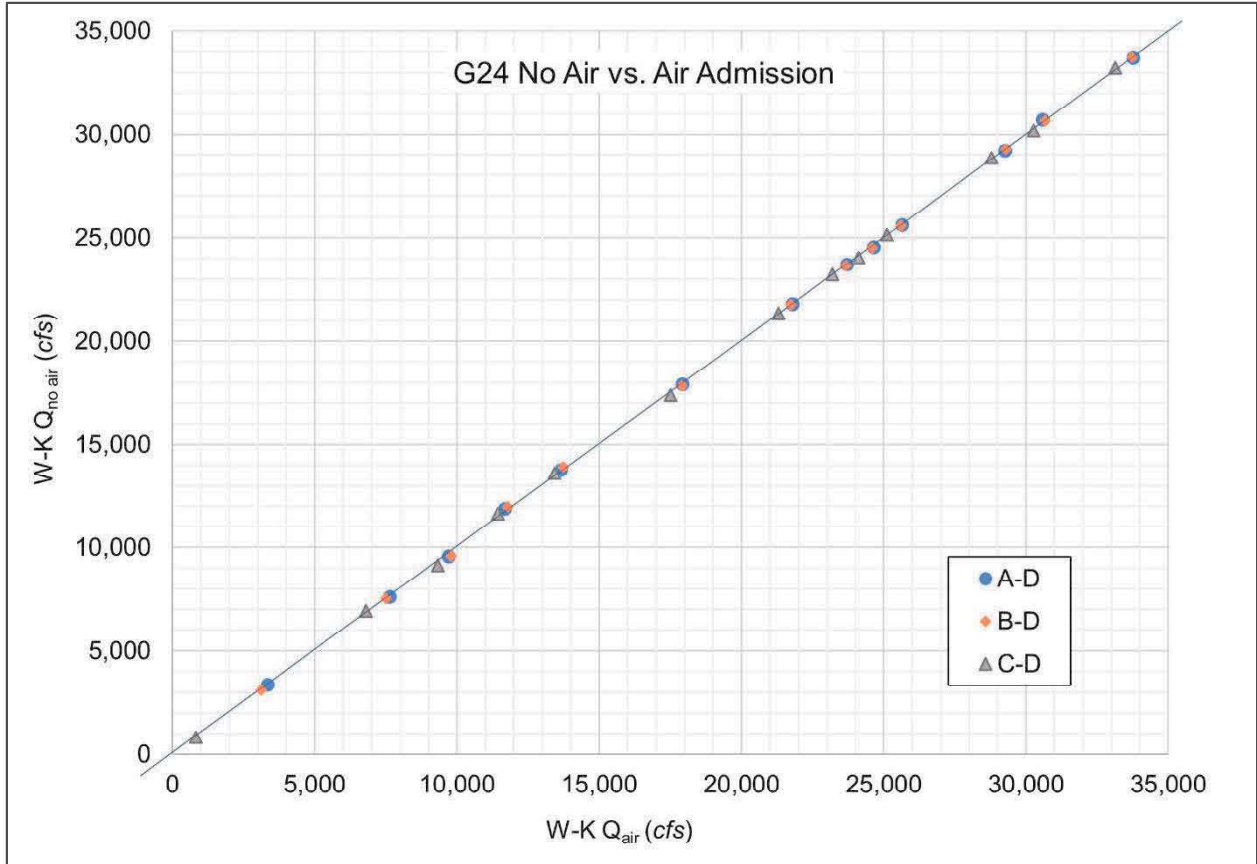

Figure 17. Comparison of G24 discharge estimates from WK pressure tap readings with and without air injected to the turbine runner during testing.

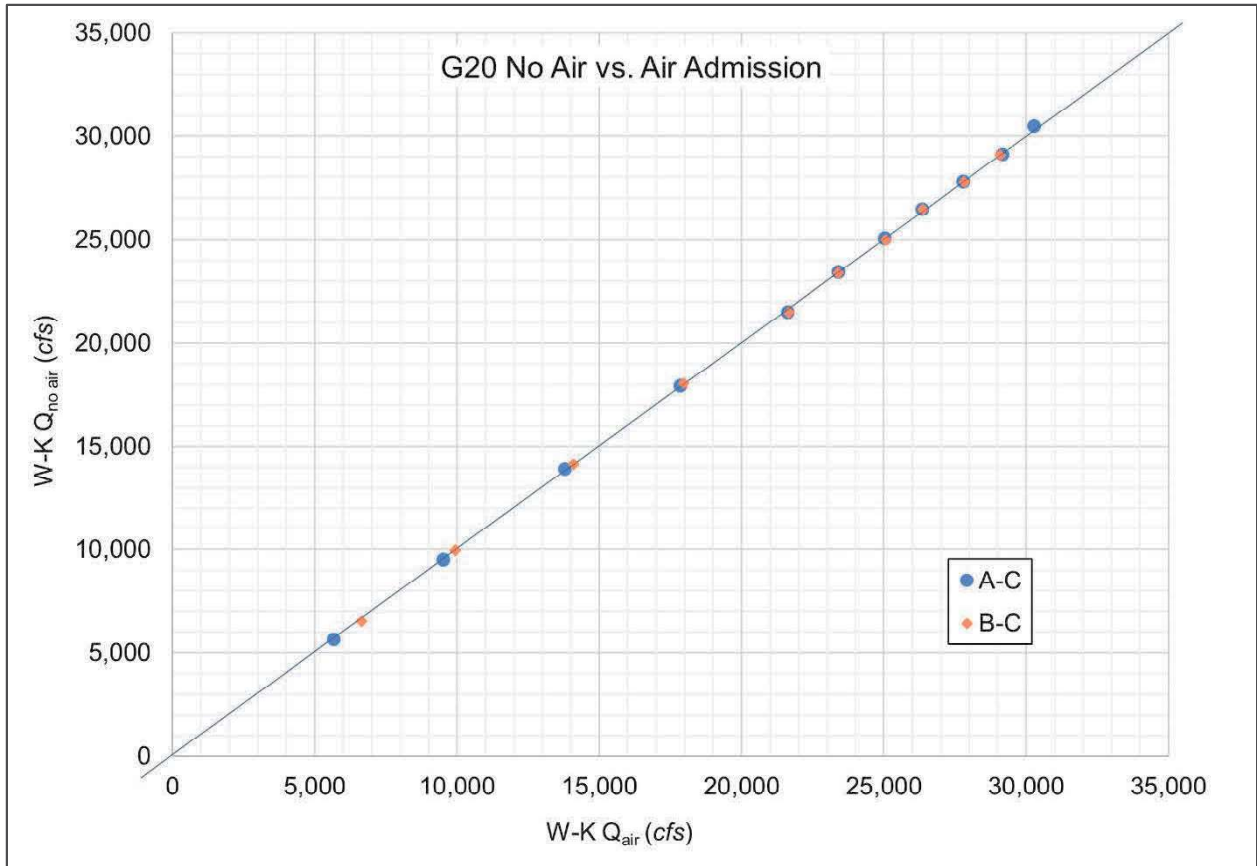

Figure 18. Comparison to G20 discharge estimates from WK pressure tap readings with and without air injected to the turbine runner during testing.

## Practical Considerations

While new WK flow equation coefficients have been established for all pressure tap configurations for both G24 and G20, some practical aspects of measuring the differential pressures are also important to produce an accurate discharge reading. First is the condition of the pressure taps in the scroll case. These should be flush with the inside surface with no irregularities in the vicinity of the taps that would affect the local pressure. These may include wear, coating damage, welding, or other surface flaws. Larger scale modifications to the intake, penstock, scroll case, or turbine runner that could alter the flow distribution at the pressure taps could also affect the WK flow measurements (Rau & Eissner, 2014). Any changes to or near the pressure taps will warrant a new test to reestablish flow coefficients.

Correct operation of the differential pressure sensors is also important for accurate measurements. Care should be taken to avoid over pressurizing one side of the sensor by opening flow from one tap before the other. When opening valves on the piping both sides of the sensor should be pressurized evenly. Built-in valves on the sensor manifold (different than the shutoff valves of the piping manifold) will help facilitate this. When starting up, flow should be allowed to flush from each pressure tap for several minutes to ensure all air bubbles and debris have been removed from the tap piping.

Any of the pressure tap configurations may be used for WK flow measurement if the respective coefficient and exponent are applied to the flow equation correctly. It may be preferred to use the first configuration for flow measurements (A-D for G24 and A-C for G20) as they provide the greatest range of differential pressures to be measured.

## Conclusions and Recommendations

Flow (Accusonic flow meter) and differential pressure (Winter-Kennedy taps) readings were recorded over a range of operating conditions with and without air injection on units G24 and G20 in the Grand Coulee Third Powerhouse concurrently with testing for unit efficiency. These measurements established new coefficients and exponents for the Winter-Kennedy flow equation for each unit and each respective pressure tap configuration. Uncertainties associated with these flow measurements were also estimated for each configuration. The coefficients and exponents determined for G24 replace those previously established from 1983 testing. Air injection at the turbine runner did not affect the Winter-Kennedy readings. Any modifications to key components of the penstock that may alter flow conditions near the Winter-Kennedy taps (e.g., surface irregularities, coating damage, welding, etc.) will likely affect pressure readings and require recalibration.

## References

- Coleman, & Steele. (1999). *Experimentation and Uncertainty Analysis for Engineers, 2nd Edition*. New York: John Wiley & Sons Inc.
- Heigel, L., Lewey, A. B., & Favero, J. P. (1984). *Turbine Performance Test Unit G24, Report No. HM-25*. Denver, CO: Bureau of Reclamation, Department of the Interior.
- Rau, T., & Eissner, M. (2014). Experience with Winter-Kennedy Coefficients on Hydraulic Identical Units. *The 10th International Conference on Hydraulic Efficiency Measurements*. Itajuba, Brazil .
- The American Society of Mechanical Engineers. (2011). *ASME PTC 18-2011, Hydraulic Turbines and Pump-Turbines, Performance Test Codes*. New York, NY: ASME.
- Winter, I. A., & Kennedy, A. M. (1933). Improved type of flow meter for hydraulic turbines. *American Society of Civil Engineers*, 59(4).



# **Appendix C**

Original Winter-Kennedy Test Data



## Grand Coulee Third Powerplant Unit G24

Table 12. - Turbine discharge index calibration, turbine performance test -  
Grand Coulee Third Powerplant, Unit G24

Run No.	Servomotor opening %	Total Discharge ft <sup>3</sup> /s	Piezometer differentials		
			A-D Hg, in	B-D Hg, in	C-D Hg, in
15	80.29	28367	12.96	12.30	9.42
16	85.72	30193	14.86	12.80	10.60
17	89.70	31312	15.90	13.82	11.56
18	94.67	32837	17.22	15.08	12.68
19	99.70				
20	99.71	34210	19.08	16.48	13.54
21	99.69	34409	18.90	16.24	13.50
22	94.64	32721	17.52	15.00	12.38
23	90.50	31725	16.14	13.98	11.56
24	84.68	29960	14.46	12.54	10.48
25	79.39	27780	12.72	11.10	9.24
26	75.00	25606	11.32	9.84	8.24
27	69.79	24419	9.90	8.40	7.02
28	65.08	23008	8.50	7.40	6.16
29	59.99	21165	7.20	6.22	5.18
30	55.17	19468	5.96	5.20	4.38
31	50.39	17187	4.80	4.24	3.56
32	49.74	17127	4.68	4.08	3.48
33	55.20	18912	6.00	5.14	4.26
34	59.70	21165	7.22	6.48	5.26
35	64.68	22680	8.48	6.48	6.20
36	69.59	24435	9.66	8.36	6.96
37	74.50	26092	11.16	9.70	8.14
38	99.69	34387	19.00	16.36	13.70
39	94.73	32935	17.44	15.20	12.66
40	89.83	31663	15.98	13.96	11.58
41	84.70	30130	14.38	12.50	10.52
42	79.80	27966	12.74	11.18	9.36
43	75.10	26256	11.44	10.12	8.34
44	69.84	24714	9.72	8.50	7.14
45	64.91	22870	8.46	7.28	6.08
46	59.71	21007	7.18	6.30	5.18
47	54.80	19154	5.94	5.12	4.32
48	50.10	17003	4.82	4.16	3.40
49	39.52	13225	2.98	2.52	2.04
50	29.61	9326	1.40	1.20	1.00
51	29.94	9304	1.44	1.28	1.00
52	39.97	12967	2.96	2.54	2.06

### Ground Coulee Third Powerplant Taps A-D

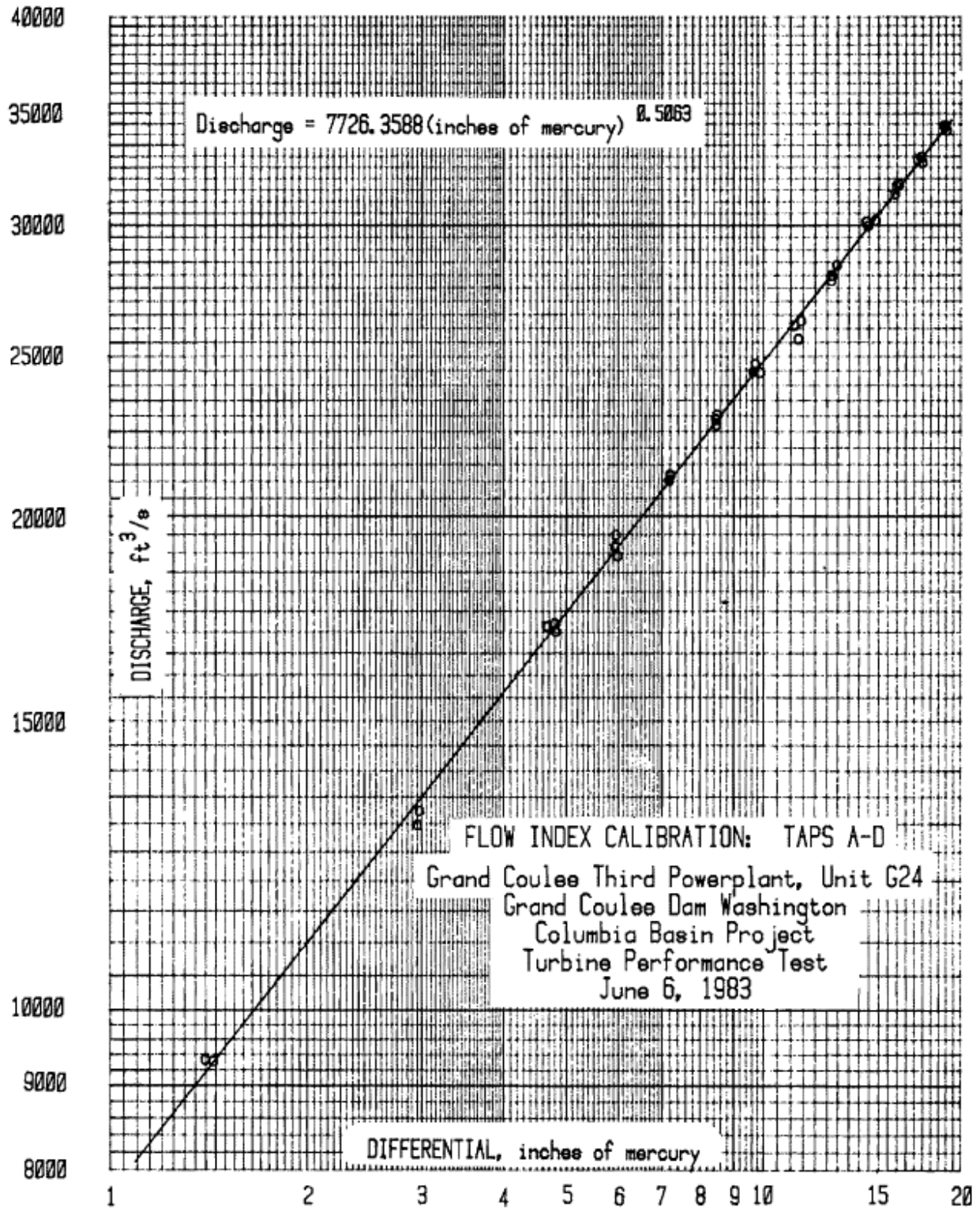

Figure 4. - Flow index calibration - taps A-D.

### Grand Coulee Third Powerplant Taps B-D

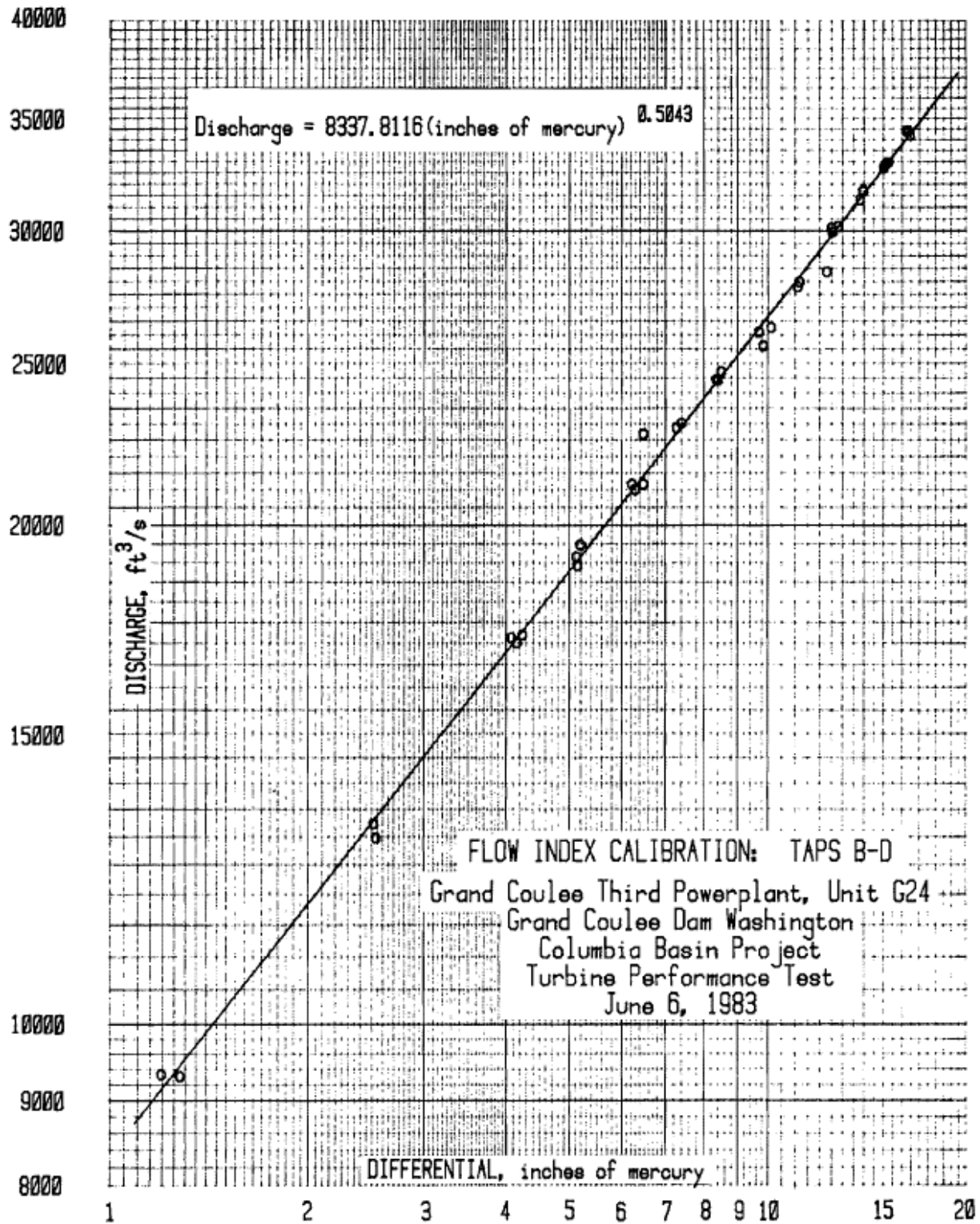

Figure 5. - Flow index calibration - taps B-D.

**Grand Coulee Third Powerplant Taps C-D**

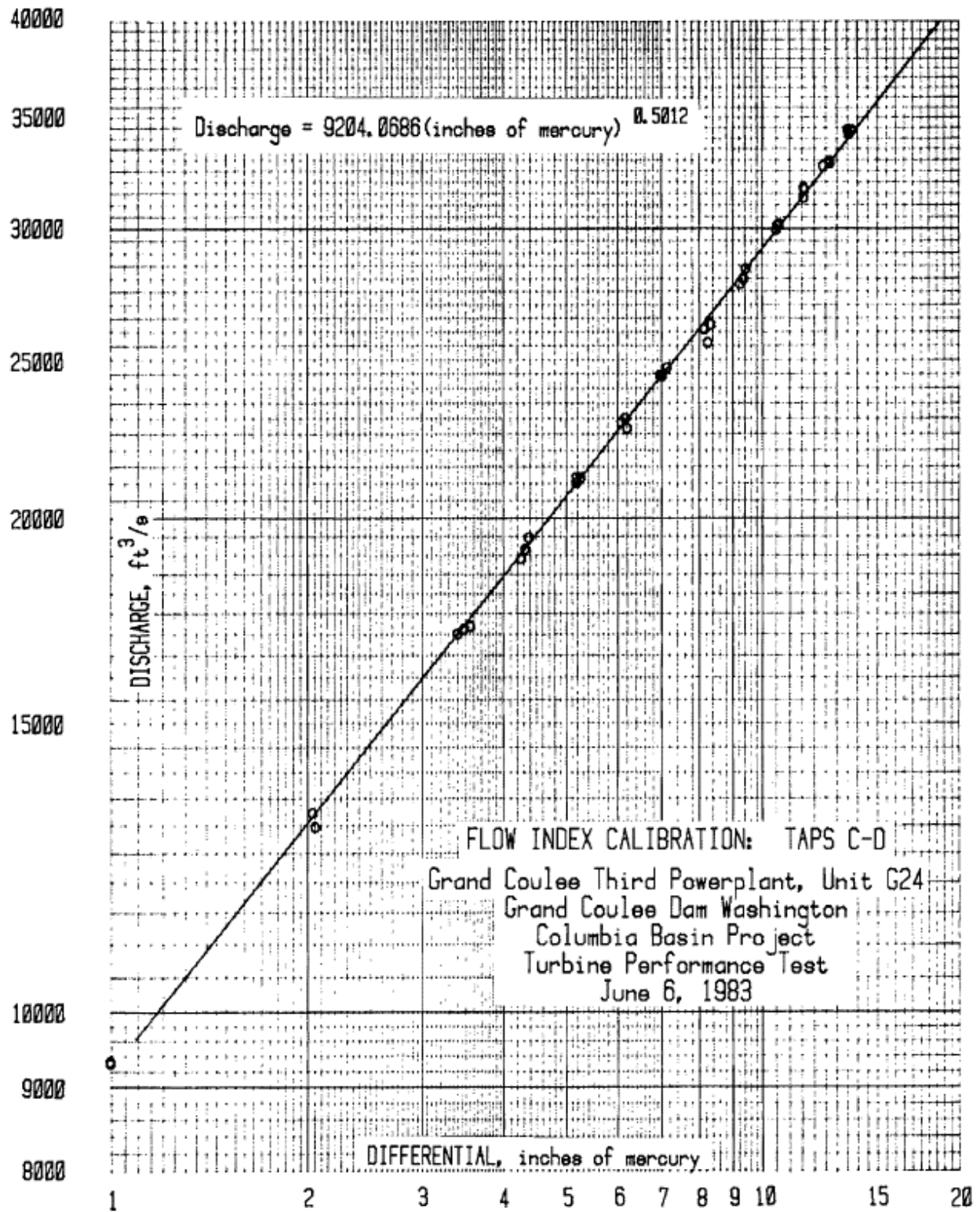
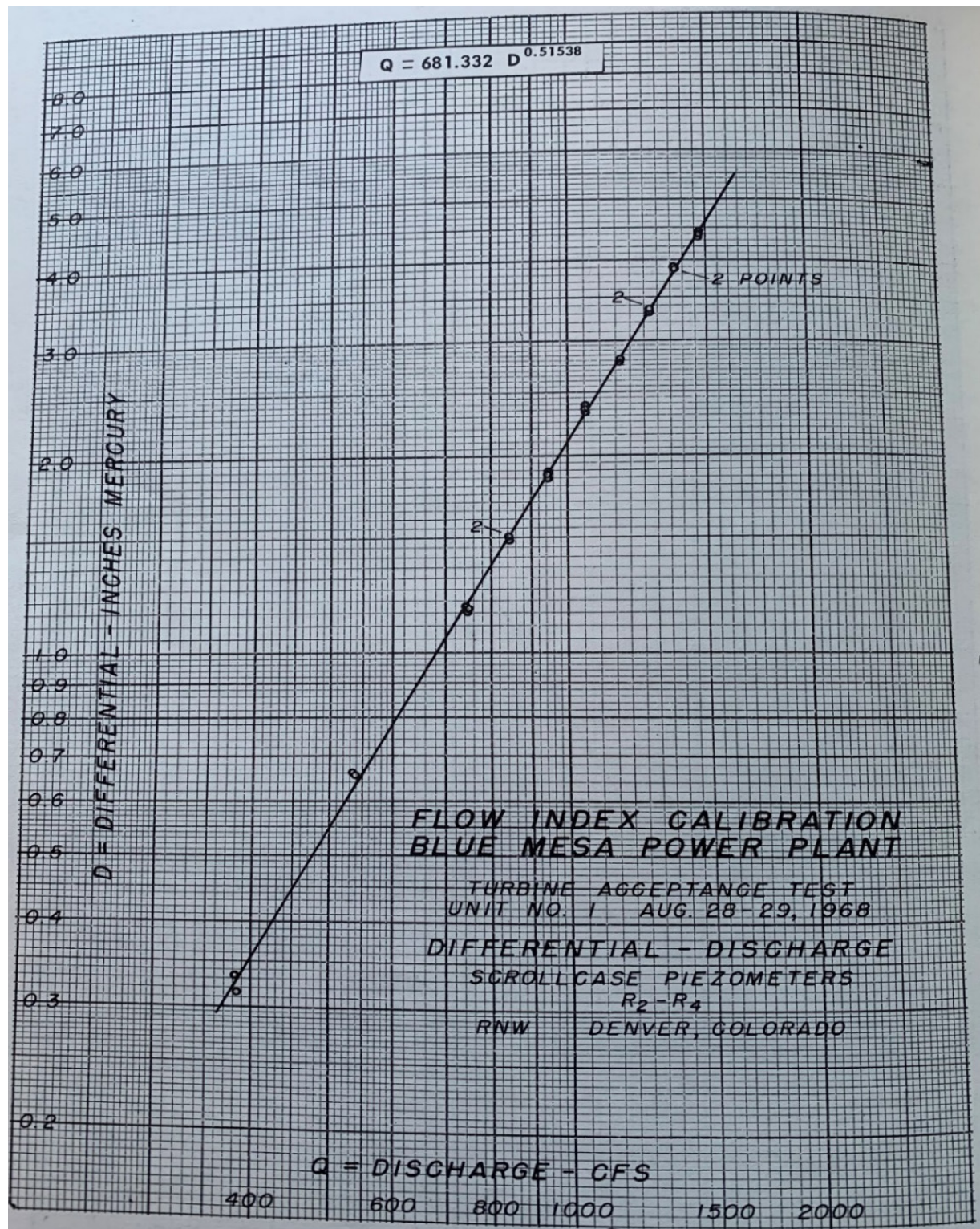

Figure 6. - Flow index calibration - taps C-D.

## Blue Mesa Powerplant Unit 1

Run No.	Discharge cfs	Differential - inches of mercury	
		$R_1 - R_4$	$R_2 - R_4$
1	--	3.166	
2	--	2.522	2.344
3	--	1.546	1.900
4	--	0.880	1.180
5	383.3	0.418	0.636
			0.316
6	1 464.2	5.960	4.360
7	745.8	1.562	1.152
8	841.3	2.034	1.502
9	945.1	2.522	1.844
10	1 055.7	3.162	2.388
11	1 164.1	3.786	2.812
12	1 271.4	4.528	3.356
13	1 370.7	5.260	3.862
14	*1 485.7	6.180	4.648
15	<u>534.7</u>	0.874	0.660
16	382.7	0.438	0.332
17	538.1	0.864	0.616
18	749.2	1.584	1.168
19	841.8	1.994	1.512
20	940.6	2.507	1.870
21	1 055.9	3.150	2.328
22	1 162.1	--	--
23	1 268.1	4.532	3.308
24	1 363.1	5.222	3.910
25	1 470.6	6.024	4.400
26	*1 484.5	6.214	4.564
27	<u>743.5</u>	1.584	1.174
28	843.0	2.014	1.484
29	945.5	2.546	1.894
30	1 051.0	3.148	2.348
			2.778
31	1 158.3	3.770	3.358
32	1 267.1	4.556	3.876
33	1 366.8	5.284	4.438
34	1 469.2	5.998	

\*These discharges not used.



## Yellowtail Powerplant Unit 2

YELLOWTAIL POWERPLANT  
TURBINE ACCEPTANCE TEST  
FLOW INDEX CALIBRATION TABULATION

Run No.	Discharge cfs	Differential--Inches of mercury		
		$P_1 - P_4$	$P_2 - P_4$	$P_1 - P_3$
4	1 962.0			
5	1 632.8	9.252	6.489	7.148
6	1 256.0	6.558	4.564	4.978
7	1 391.7	3.988	2.798	3.112
8	872.1	4.762	3.326	3.800
9	1 119.9	2.000	1.370	1.576
10	1 377.0	3.210	2.230	2.518
11	1 517.3	4.800	3.336	3.728
12	1 626.9	5.644	3.930	4.328
13	1 740.4	6.468	4.484	4.986
14	1 846.6	7.316	5.082	5.586
15	1 945.4	8.242	5.716	6.378
16	--	9.206	6.456	7.136
17	--	10.136	7.184	7.958
18	1 844.3	11.624	8.112	9.034
19	1 740.9	8.240	5.738	6.320
20	1 622.3	7.244	5.070	5.563
21	1 515.1	6.434	4.470	4.968
22	2 189.7	5.554	3.904	4.442
23	--	11.652	8.232	9.078
24	1 260.8	10.146	7.152	7.896
25	1 115.9	3.944	2.758	2.988
26	1 391.5	3.172	2.236	2.388
27	1 512.9	4.738	3.292	3.642
28	1 633.0	--	--	--
29	1 741.3	--	--	--
30	--	--	--	--
31	1 129.9	--	--	--
32	1 262.3	--	--	--
33	631.2	--	--	--
34	868.6	--	--	--

Runs 1-3 are preliminary runs  
Runs 35-37 are motoring runs  
Differentials were not obtained for runs 27-34

### Yellowtail Powerplant Taps P<sub>1</sub>-P<sub>4</sub>

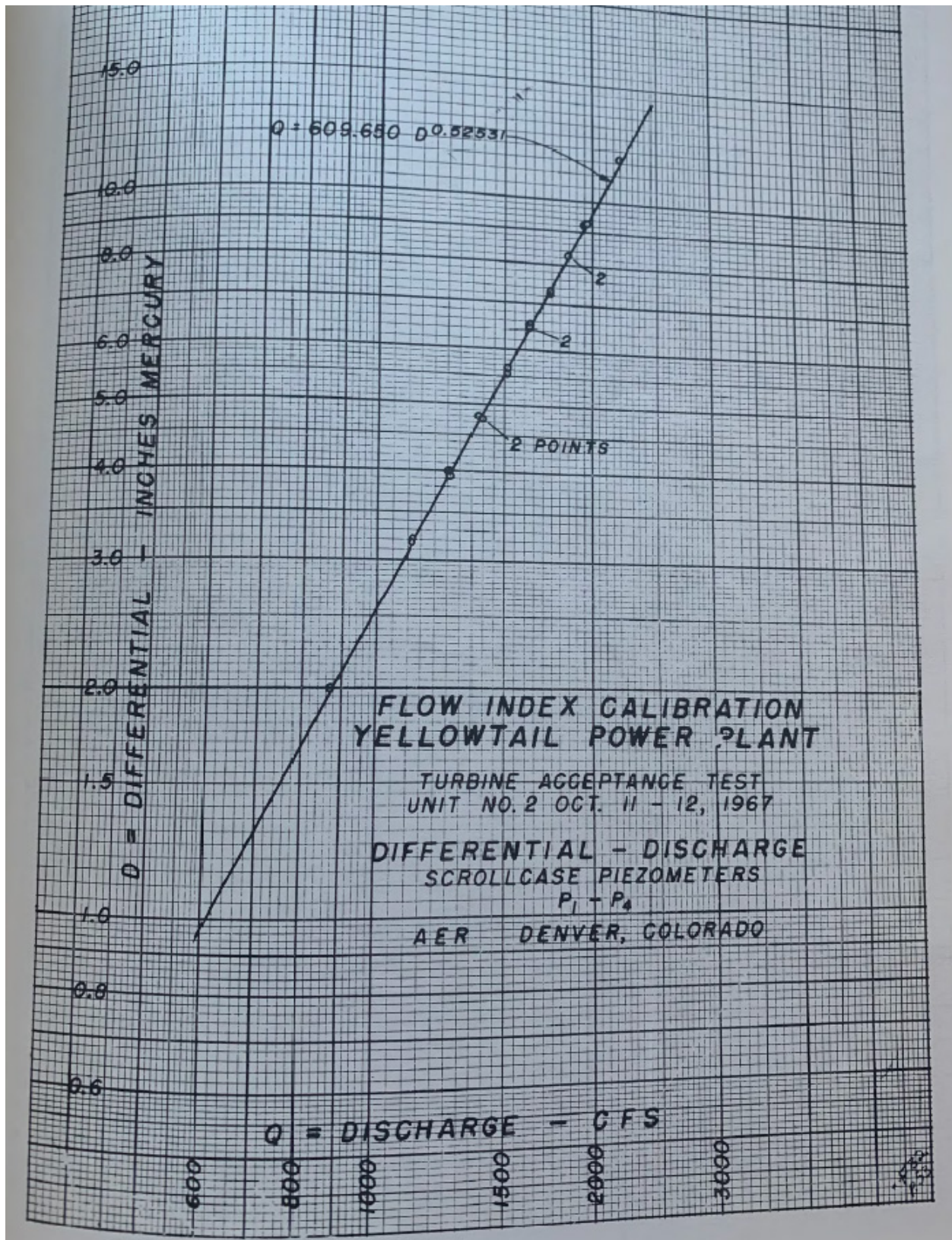

### Yellowtail Powerplant Taps P<sub>1</sub>-P<sub>3</sub>

